

INDEX

HYDRAULIC LASH ADJUSTER (HLA)
INSPECTION, PAGE B1-6

COMPRESSION
INSPECTION, PAGE B1-6

STANDARD: 1,197 kPa (12.2 kg/cm², 173 psi)-300 rpm
MINIMUM: 838 kPa (8.5 kg/cm², 121 psi)-300 rpm

EXHAUST MANIFOLD
TIGHTENING TORQUE
22-28 N·m (2.2-2.9 m·kg, 16-21 ft·lb)

INTAKE MANIFOLD
TIGHTENING TORQUE
19-25 N·m (1.9-2.6 m·kg, 14-19 ft·lb)

ENGINE COOLANT INSPECTION,
SERVICE, SECTION E

ENGINE OIL INSPECTION,
SERVICE, SECTION D

DRIVE BELT ADJUSTING, PAGE B1-5

DEFLECTION

mm (in)

DRIVE BELT	NEW	USED
ALTERNATOR	7.0-8.0 (0.28-0.31)	8.0-9.0 (0.31-0.35)
P/S OIL PUMP	7.0-8.0 (0.28-0.31)	8.0-9.0 (0.31-0.35)
A/C COMPRESSOR	10.0-12.0 (0.39-0.47)	12.0-14.0 (0.47-0.55)

9BU0B1-002

1. Engine

Removal page B1-20
Disassembly page B1-24
Inspection and Repair page B1-34
Assembly page B1-46
Installation page B1-69

2. Timing belt

Removal page B1-8
Installation page B1-10
Inspection page B1-44

3. Cylinder head gasket

Removal page B1-13
Installation page B1-15

OUTLINE

SPECIFICATIONS

Item		Engine		F2	
				Carburetor	EGI
Type		Gasoline, 4-cycle			
Cylinder arrangement and number		In-line, 4 cylinders			
Combustion chamber		Multispherical			
Valve system		OHC, belt-driven			
Displacement		cc (cu in)	2,184 (133.22)		
Bore x stroke		mm (in)	86.0 x 94.0 (3.39 x 3.70)		
Compression ratio		8.6			
Compression pressure		kPa (kg/cm ² , psi)-rpm	1,197 (12.2, 173)-300		
Valve timing	IN	Open	BTDC	13°	
		Close	ABDC	57°	
	EX	Open	BBDC	58°	
		Close	ATDC	12°	
Valve clearance		IN	mm (in)	0; Maintenance free	
		EX	mm (in)	0; Maintenance free	
Idle speed	rpm	M/T (Neutral)	800 \pm 50	750 \pm 20	
		A/T (P range)	800 \pm 50	770 \pm 20	
Ignition timing (TEN terminal)		BTDC	6° \pm 1° at idle		
Firing order		1-3-4-2			

B1

2BU0B1-002

TRUBLESHOOTING GUIDE

Problem	Possible Cause	Remedy	Page
Difficult starting	Malfunction of engine-related components Burned valve Worn piston, piston ring, or cylinder Failed cylinder head gasket	Replace Replace or repair Replace	B1-35 B1-40, 42 B1-13
	Malfunction of fuel system	Refer to Section F	
	Malfunction of electrical system	Refer to Section G	
	Poor idling	Malfunction of engine-related components Malfunction of HLA Poor valve-to-valve seat contact Failed cylinder head gasket	Replace Repair or replace Replace
Malfunction of fuel system		Refer to Section F	
Malfunction of ignition system		Refer to Section G	
Excessive oil consumption		Oil working up Worn piston ring groove or sticking piston ring Worn piston or cylinder	Replace Replace or repair
	Oil working down Worn valve seal Worn valve stem or guide	Replace Replace	B1-57 B1-35
	Oil leakage	Refer to Section D	

Problem	Possible Cause	Remedy	Page
Insufficient power	Insufficient compression Malfunction of HLA Compression leakage from valve seat Seized valve stem Weak or broken valve spring Failed cylinder head gasket Cracked or distorted cylinder head Sticking, damaged, or worn piston ring Cracked or worn piston	Replace Repair Replace Replace Replace Replace Replace Replace	B1-40 B1-37 B1-35 B1-38 B1-13 B1-34 B1-42 B1-42
	Malfunction of fuel system	Refer to Sections F1, F2	
	Malfunction of ignition system	Refer to Section G	
	Others Slipping clutch Dragging brakes Wrong size tires	Refer to Section H Refer to Section P Refer to Section Q	
	Malfunction of engine-related components Malfunction of HLA Sticking or burned valve Weak or broken valve spring Carbon accumulation in combustion chamber	Replace Replace Replace Eliminate carbon	B1-40 B1-35 B1-38 —
Abnormal combustion	Malfunction of fuel system	Refer to Sections F1, F2	
	Malfunction of ignition system	Refer to Section G	
	Crankshaft or bearing related parts Excessive main bearing oil clearance Main bearing seized or heat-damaged Excessive crankshaft end play Excessive connecting rod bearing oil clearance Connecting rod bearing seized or heat-damaged	Replace or repair Replace Replace or repair Replace or repair Replace	B1-49 B1-44 B1-50 B1-51 B1-44
Engine noise	Piston-related parts Worn cylinder Worn piston or piston pin Seized piston Damaged piston ring Bent connecting rod	Replace or repair Replace Replace Replace Replace	B1-40 B1-43 B1-42 B1-42 B1-43
	Valves or timing-related parts Malfunction of HLA* Broken valve spring Excessive valve guide clearance Insufficient lubrication of rocker arm	Replace Replace Replace Replace	B1-40 B1-38 B1-35 B1-40
	Malfunction of cooling system	Refer to Section E	
	Malfunction of fuel system	Refer to Sections F1, F2	
	Others Malfunction of water pump bearing Improper drive-belt tension Malfunction of alternator bearing Exhaust gas leakage Malfunction of timing belt tensioner	Refer to Section E Adjust Refer to Section G Refer to Sections F1, F2 Replace	B1- 5 B1- 8

2BU0B1-003

* Tappet noise may occur if the engine is not operated for an extended period. The noise should disappear after the engine has reached normal operating temperature.

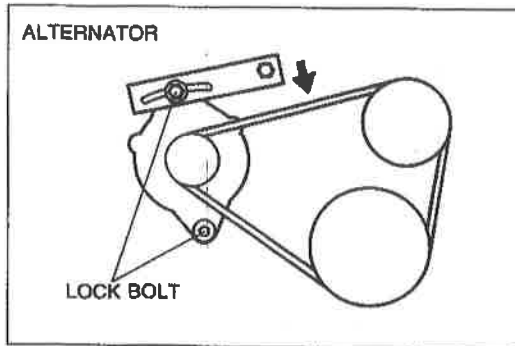

9BU0B1-0B1

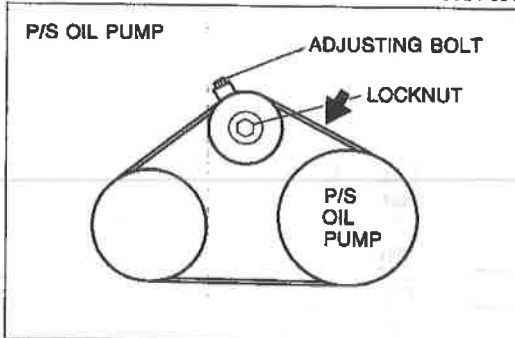

0BU0B1-002

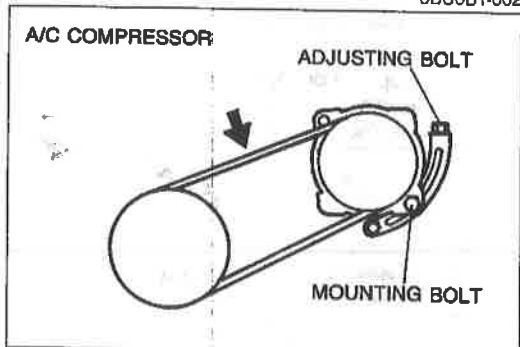

0BU0B1-018

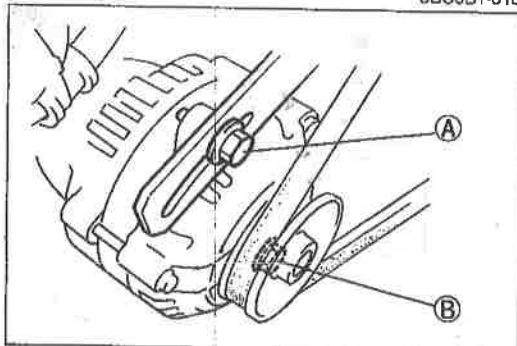

0BU0B1-019

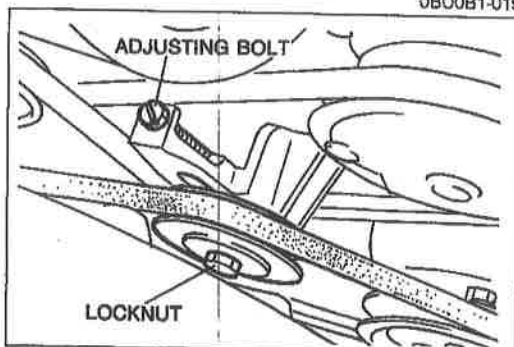

9MU0B2-009

ENGINE TUNE-UP PROCEDURE

DRIVE BELT

1. Check the drive belts for wear, cracks, or fraying; replace if necessary.
2. Check the drive belt deflection by applying moderate pressure (**98 N, 10 kg, 22 lb**) midway between the pulleys shown in the figure. Adjust if necessary.

B1

Deflection

mm (in)

Drive belt	New	Used
Alternator	7.0—8.0 (0.28—0.31)	8.0—9.0 (0.31—0.35)
P/S oil pump	7.0—8.0 (0.28—0.31)	8.0—9.0 (0.31—0.35)
A/C compressor	10.0—12.0 (0.39—0.47)	12.0—14.0 (0.47—0.55)

3. Check the drive belt tension with the tension gauge.

Note

Belt tension can be measured among any pulleys.

Tension

N (kg, lb)

Drive belt	New	Used
Alternator	491—540 (50—55, 110—121)	392—491 (40—50, 88—110)
P/S oil pump	245—294 (25—30, 55—66)	196—245 (20—25, 44—55)
A/C compressor	441—540 (45—55, 99—121)	343—441 (35—45, 77—99)

Adjustment

- (1) Alternator belt
If necessary, loosen the alternator bolts and adjust the belt deflection.

Tightening torque

Bolt A: 31—46 N·m (3.2—4.7 m·kg, 23—34 ft·lb)
Bolt B: 37—52 N·m (3.8—5.3 m·kg, 27—38 ft·lb)

- (2) P/S oil pump belt
If necessary, loosen the locknut and adjust the belt deflection by turning the adjusting bolt.

Tightening torque:

37—52 N·m (3.8—5.3 m·kg, 27—38 ft·lb)

B1

ENGINE TUNE-UP PROCEDURE, COMPRESSION

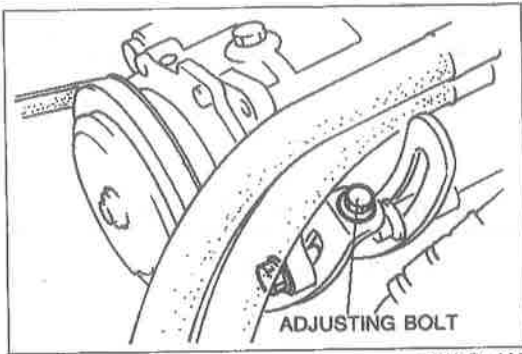

9BU0B1-008

- (3) A/C compressor belt
If necessary, loosen the mounting bolts and adjust the belt deflection by turning the adjusting bolt.

Tightening torque:
37—52 N·m (3.8—5.3 m·kg, 27—38 ft·lb)

HLA TROUBLESHOOTING GUIDE

Problem	Possible Cause	Action
1. Noise when engine is started immediately after oil is changed. 2. Noise when engine is started after setting approx. one day.	Oil leakage in oil passage	Run engine at 2000—3000 rpm. If noise stops after 2 second—10 minutes*, HLA is normal. If not, replace HLA.
3. Noise when engine is started after cranking for 3 seconds or more. 4. Noise when engine is started after new HLA is installed.	Oil leakage in HLA	* Time required for engine oil to circulate within engine, includes tolerance for engine oil condition and ambient temperature.
5. Noise continues more than 10 minutes.	Insufficient oil pressure	Check oil pressure. (Refer to Section D) If lower than specification, check for cause. Oil pressure; 304—402 kPa (3.1—4.1 kg/cm², 44—58 psi)-3000 rpm
	Faulty HLA	(Refer to page B2-69) Press down rocker arm by hand. If it moves, replace HLA. If it does not move, HLA normal. Measure valve clearance. If more than 0mm (0 in), replace HLA.
6. Noise occurs during idle after high-speed running.	Incorrect oil amount	Check oil level. Drain or add oil as necessary.
	Deteriorated oil	Check oil quality. If deteriorated, replace with specified type and amount of oil.

2BU0B1-008

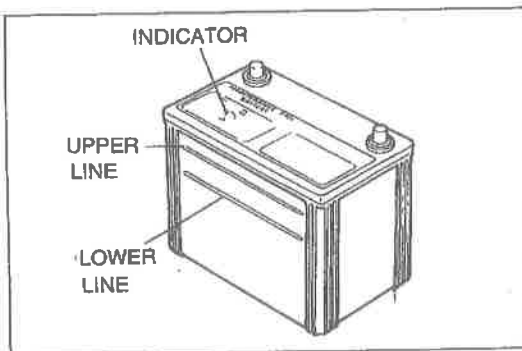

2BU0B1-009

COMPRESSION

If the engine exhibits low power, poor fuel economy, or poor idle, check the following:

1. Ignition system (Refer to Section G.)
2. Compression
3. Fuel system (Refer to Sections F1, F2.)

COMPRESSION

1. Check that the battery is fully charged. Recharge it if necessary.
2. Warm up the engine to the normal operating temperature.
3. Turn it off for about 10 minutes to allow the exhaust manifold to cool.
4. Remove all spark plugs.
5. Disconnect the primary wire connector from the ignition coil.

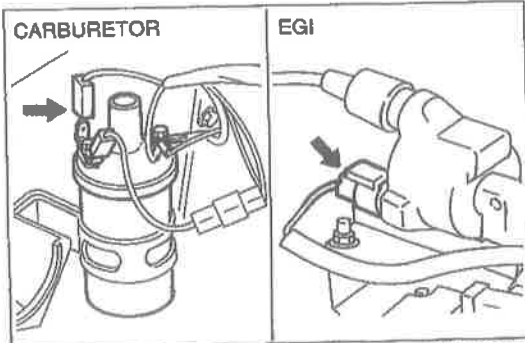

86U01X-020

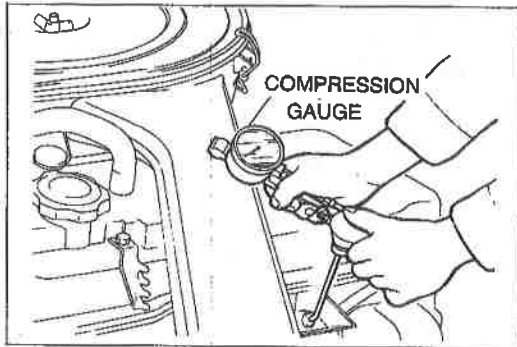

1BU0B1-001

6. Connect a compression gauge to the No.1 spark plug hole.
7. Fully depress the accelerator pedal and crank the engine.
8. Note the maximum gauge reading.
9. Check each cylinder.

Compression:

1,197 kPa (12.2 kg/cm², 173 psi)-300 rpm

Minimum:

834 kPa (8.5 kg/cm², 121 psi)-300 rpm

B1

Possible Cause

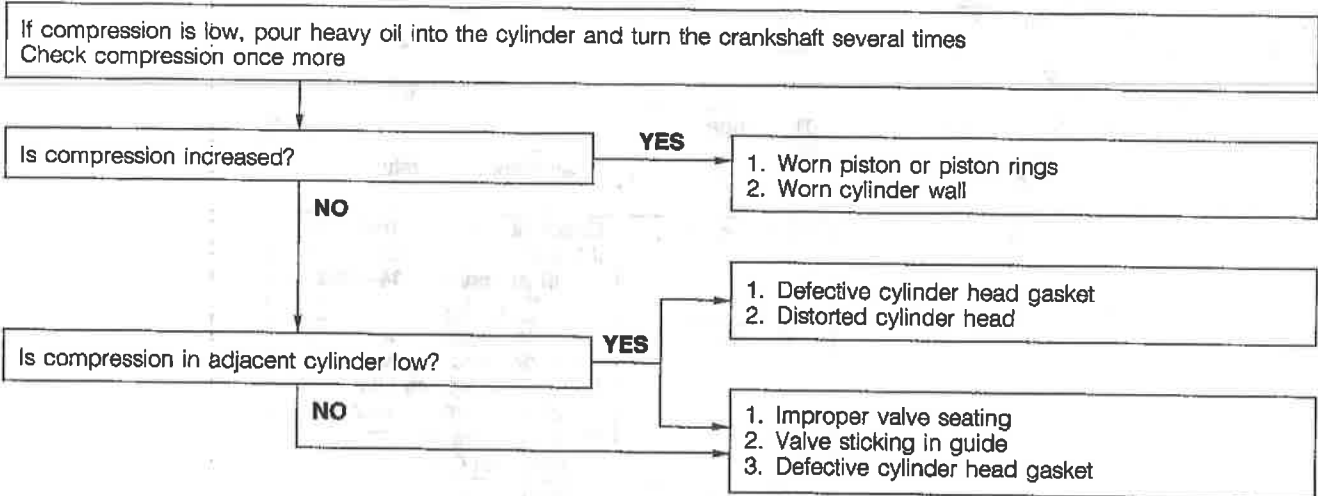

86U01X-022

ON-VEHICLE MAINTENANCE

TIMING BELT

Removal

1. Disconnect the negative battery cable.
2. Drain the engine coolant.
3. Remove in the order shown in the figure referring to the **Removal note**.

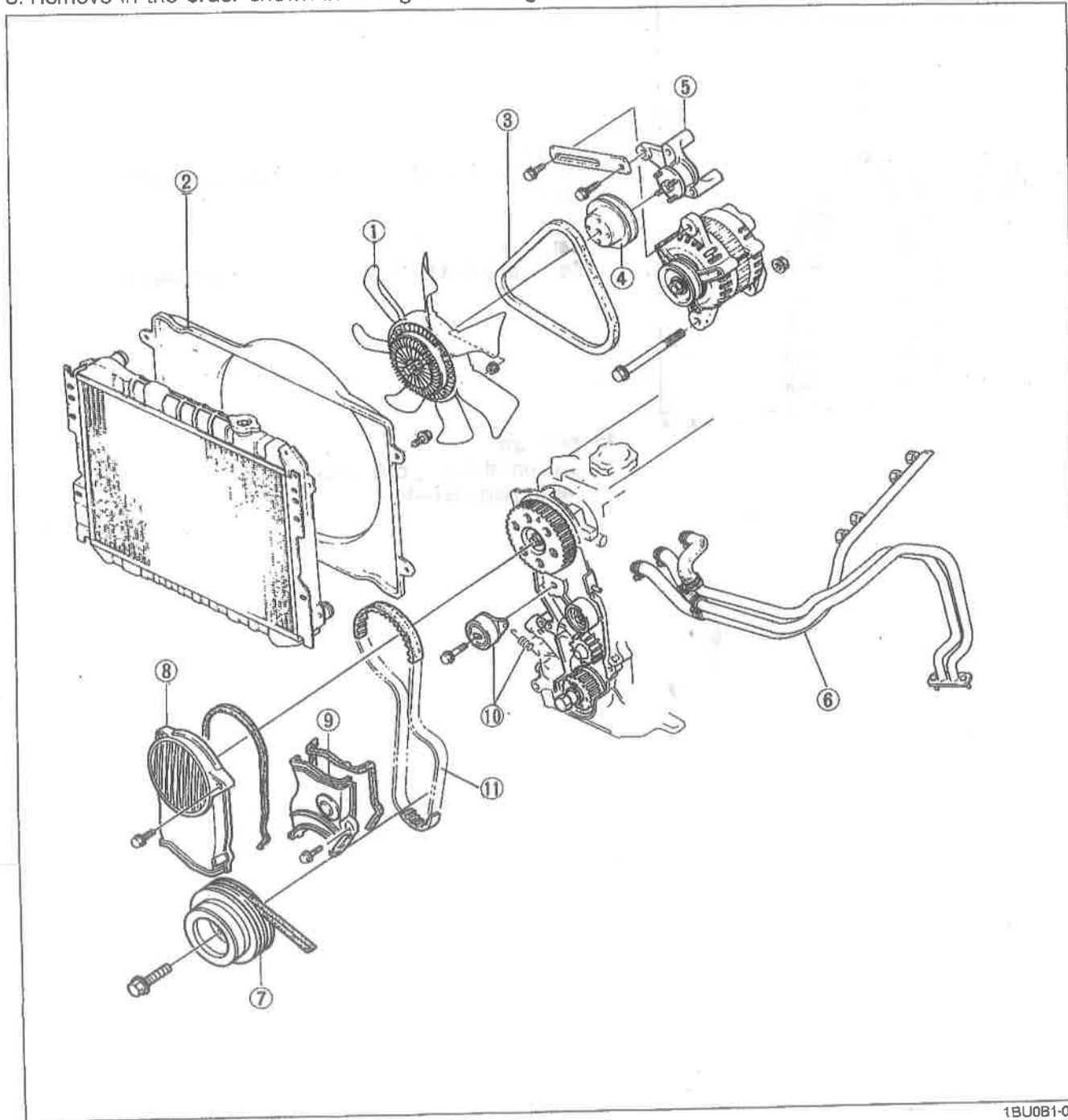

1BU0B1-002

- | | |
|---|--------------------------------------|
| 1. Cooling fan | 7. Crankshaft pulley |
| 2. Radiator cowling | 8. Timing belt cover upper |
| 3. Alternator drive belt | 9. Timing belt cover lower |
| 4. Cooling fan pulley | 10. Timing belt tensioner and spring |
| 5. Cooling fan bracket | 11. Timing belt |
| 6. Secondary air pipe assembly (Carburetor) | |

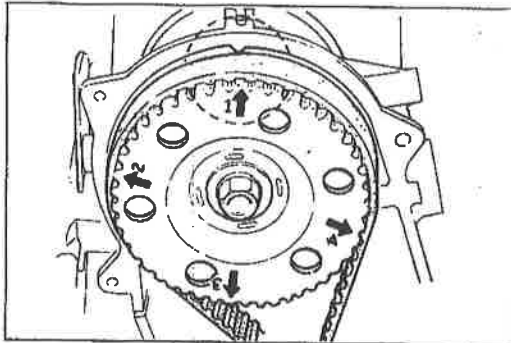

9BU0B1-013

Removal note

Timing belt tensioner

1. Turn the crankshaft to align the ↑1 mark of the camshaft pulley with the front housing matching mark.
2. Remove the tensioner and spring.

B1

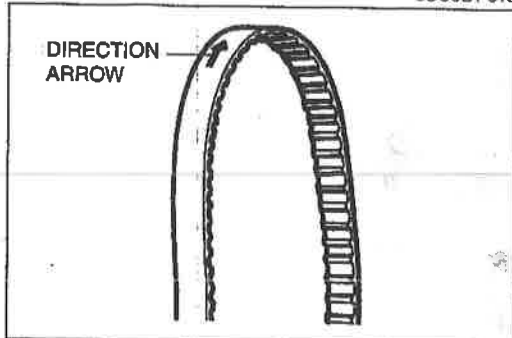

86U01X-024

Timing belt

Mark the timing belt rotation for proper reinstallation if it is reused.

Caution

Be careful not to allow oil, grease, or water on the belt.

Inspection

Inspection of timing belt related parts.
(Refer to page B1-44.)

9BU0B1-014

Installation

Install in the reverse order of removal referring to the **Installation note**.

Caution

After radiator cowl installation, rotate the cooling fan by hand and verify that the fan blade does not touch the radiator cowl.

If the fan touches the cowl, adjust the radiator cowl mounting position.

Note

a) Position the hose clamp in the original location on the hose.

b) Squeeze the clamp lightly with large pliers to ensure a good fit.

Torque Specifications

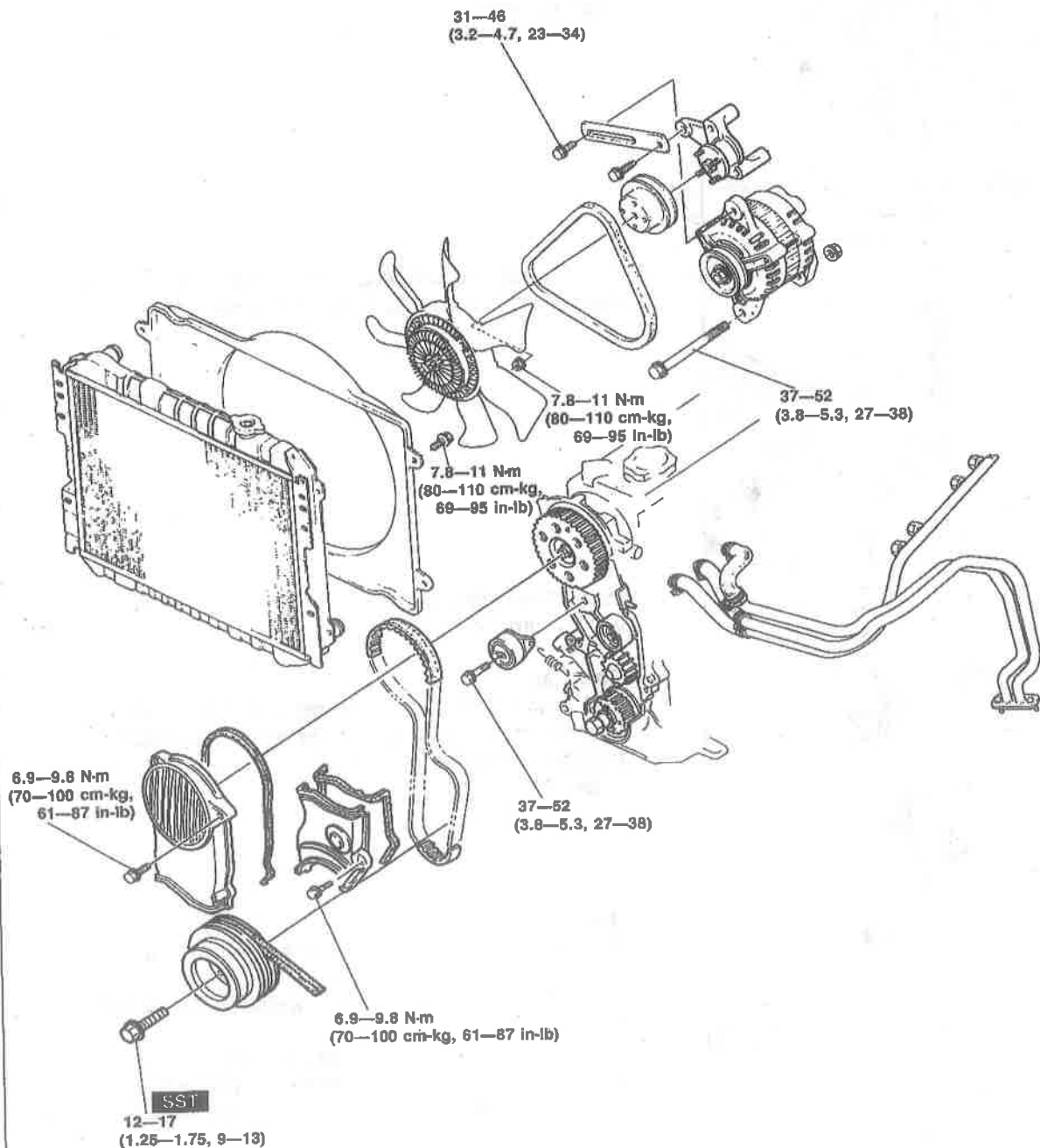

N-m (m-kg, ft-lb)

9BU0B1-015

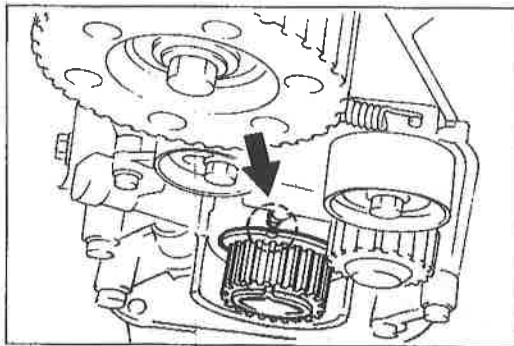

86U01X-220

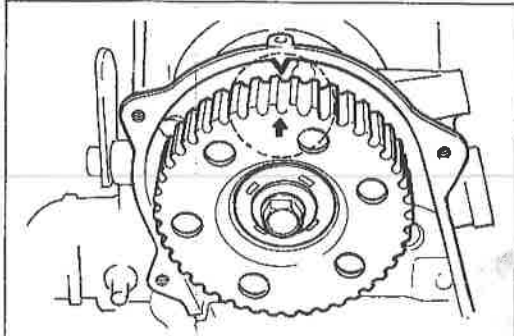

96U01X-014

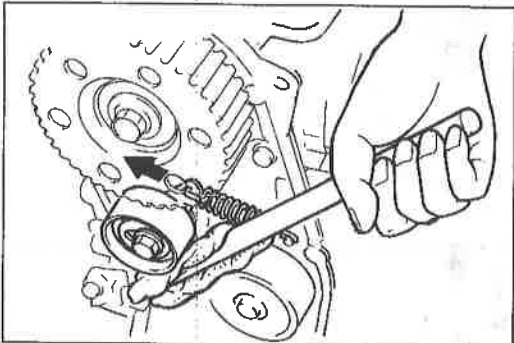

4BG01A-033

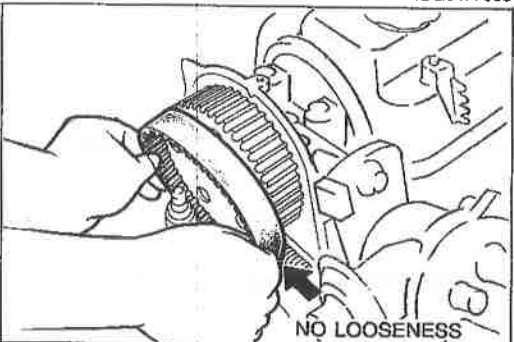

86U01X-027

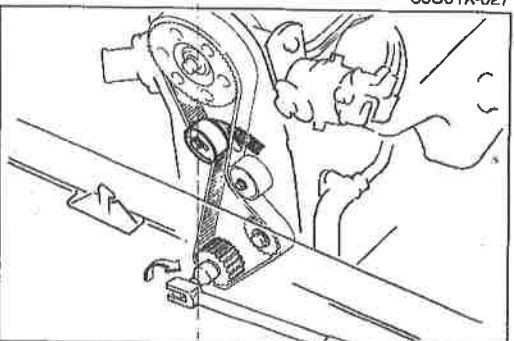

96U01X-087

Installation note

Timing belt

1. Check that the mark on the timing belt pulley is aligned with the matching mark.

2. Check that the **↑1** mark of the camshaft pulley is aligned with the matching mark. If it is not aligned, turn the camshaft to align.

3. Install the timing belt tensioner and spring. Temporarily secure it with the spring fully extended.

4. Install the timing belt so that there is no looseness at the water pump pulley and idler pulley side.

Caution

a) If the timing belt is being reused, it must be reinstalled to rotate in the original direction.

b) Check that there is no oil, grease, or dirt on the timing belt.

Note

Remove all spark plugs for easier rotation.

5. Turn the crankshaft twice clockwise in the direction of rotation.

6. Check that the matching marks are correctly aligned. If not, repeat the above-mentioned procedure.

7. Loosen the tensioner lock bolt and apply tension to the belt.

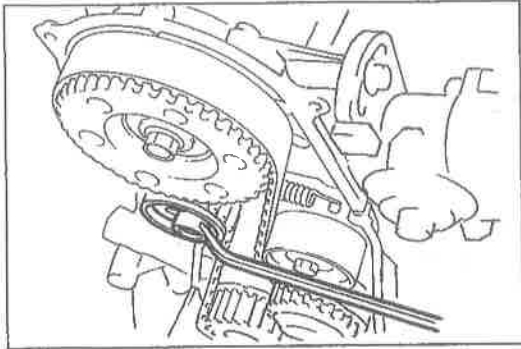

69G01B-028

8. Tighten the timing belt tensioner lock bolt.

Tightening torque:

37—52 N·m (3.8—5.3 m·kg, 27—38 ft·lb)

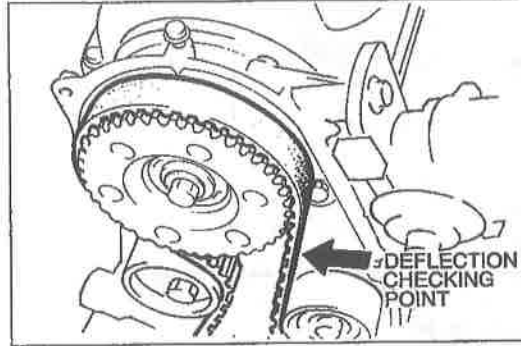

96U01X-015

9. Turn the crankshaft twice in the direction of rotation and align the matching marks.
 10. Check the timing belt deflection. If the deflection is not correct, repeat the adjustment from step 5 above.

Timing belt deflection/98 N (10 kg, 22 lb)

New : 8.0—9.0mm (0.31—0.35 in)

Used: 9.0—10.0mm (0.35—0.39 in)

Caution

Be sure not to apply tension other than that of the tensioner spring.

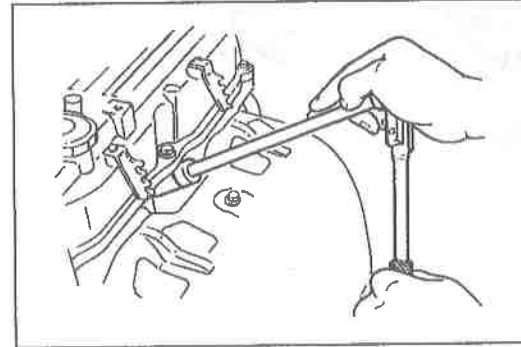

2BU0B1-010

Spark plug

1. Install the spark plugs.

Tightening torque:

15—23 N·m (1.5—2.3 m·kg, 11—17 ft·lb)

Steps After Installation

1. Adjust the drive belt tension. (Refer to page B1-5.)
2. Add engine coolant to the specified levels.
3. Connect the negative battery cable.
4. Start the engine and do the following:
 - (1) Check for leakage of engine coolant.
 - (2) Perform engine adjustments if necessary.
 - (3) Recheck the coolant levels.

9BU0B1-016

**CYLINDER HEAD GASKET
Removal**

Warning: Release the fuel pressure. (Refer to Sections F1, F2.)

1. Disconnect the negative battery cable.
2. Remove the engine undercover.
3. Drain the engine coolant.
4. Remove in the order shown in the figure referring to the **Removal note**.

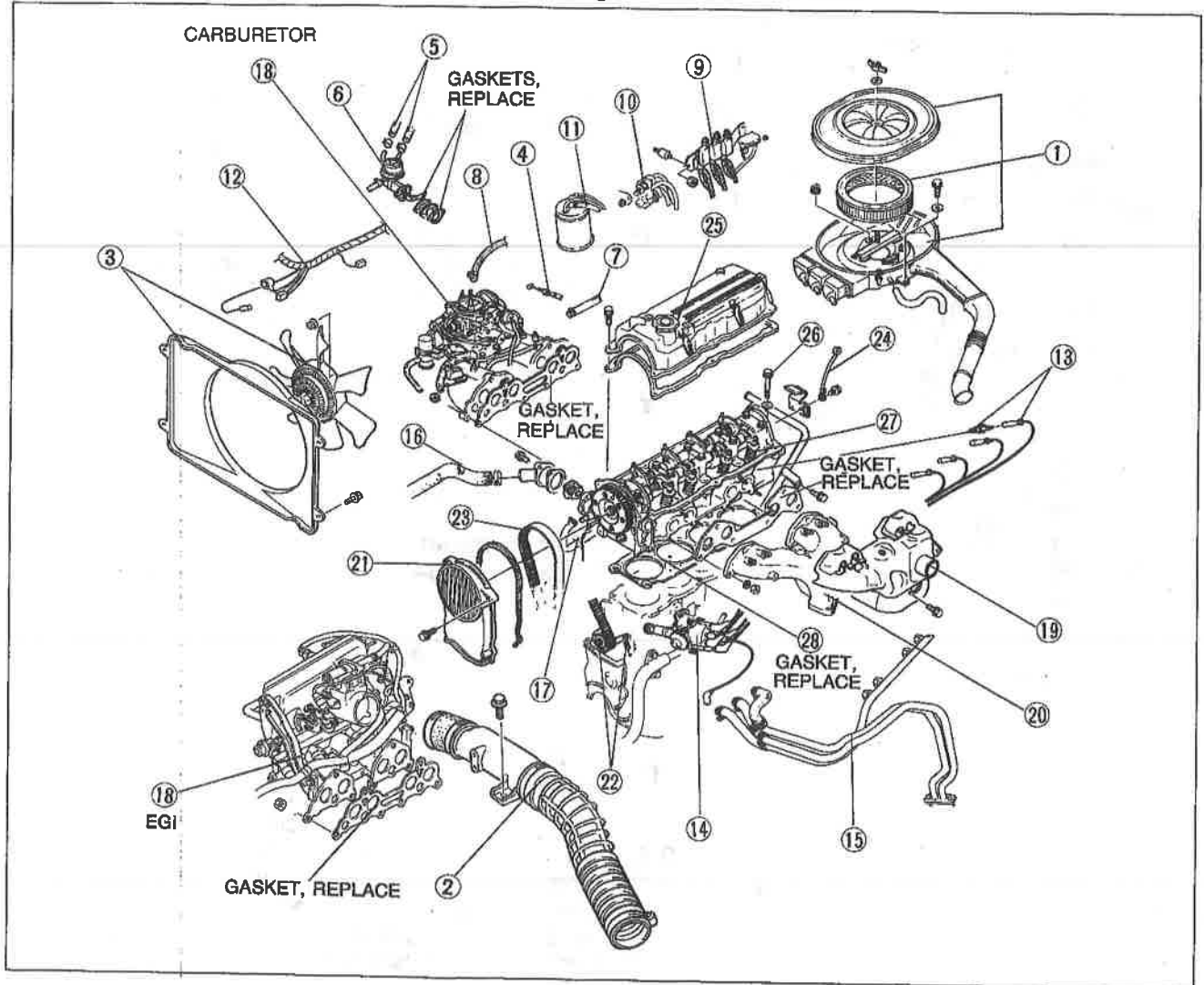

2BU0B1-011

- | | |
|---|--|
| <ol style="list-style-type: none"> 1. Air cleaner assembly (Carburetor) 2. Air intake hose (EGi) 3. Cooling fan and radiator cowling 4. Accelerator cable 5. Fuel hoses 6. Fuel pump (Carburetor M/T) 7. Heater hoses 8. Brake vacuum hose 9. Three-way solenoid valve assembly 10. Duty solenoid valve assembly 11. Canister hoses 12. Engine harness 13. High-tension leads and spark plugs 14. Distributor | <ol style="list-style-type: none"> 15. Secondary air pipe assembly (Carburetor) 16. Radiator hose, upper 17. Water by-pass hose 18. Intake manifold assembly 19. Exhaust manifold insulator 20. Exhaust manifold 21. Timing belt cover, upper 22. Timing belt tensioner and spring 23. Timing belt 24. Engine ground 25. Cylinder head cover 26. Cylinder head bolt 27. Cylinder head 28. Cylinder head gasket |
|---|--|

B1

ON-VEHICLE MAINTENANCE (CYLINDER HEAD GASKET)

CARBURETOR

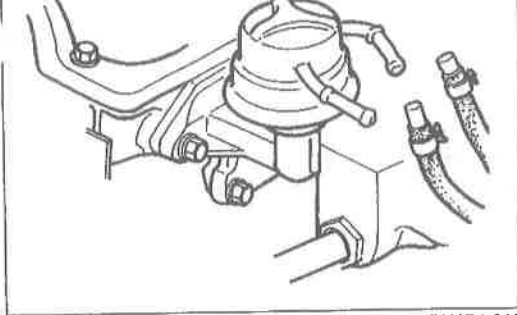

9BU0B1-019

EGI

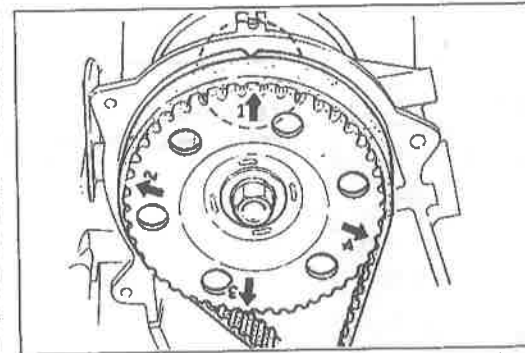
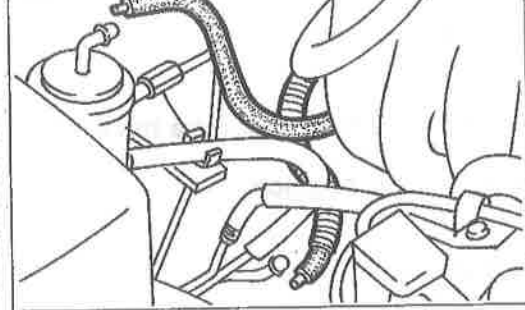

96U01X-018

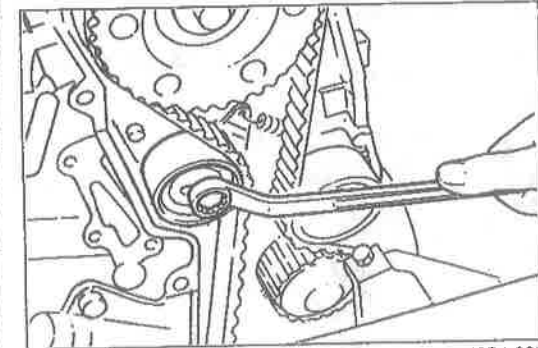

9BU0B1-020

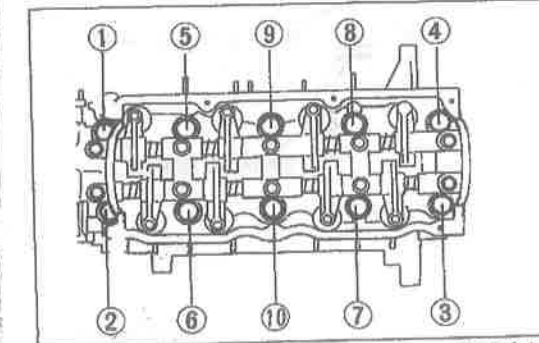

76G01A-111

Removal note Fuel hose

Note

- Cover the hose with a rag because fuel will spray out when disconnecting.
- Keep sparks and open flame away from the fuel area.

Plug the disconnected hoses to avoid fuel leakage.

Timing belt

- Before removing the timing belt, turn the crankshaft to align the **↑1** mark of the camshaft pulley with the front housing matching mark.

- Loosen the timing belt tensioner lock bolt.
- Shift the tensioner outward as far as possible, then temporarily tighten it.
- Remove the timing belt and secure it out of the way to prevent damage during removal and installation of the cylinder head.

Cylinder head bolt

Loosen the cylinder head bolts in two or three steps in the order shown in the figure.

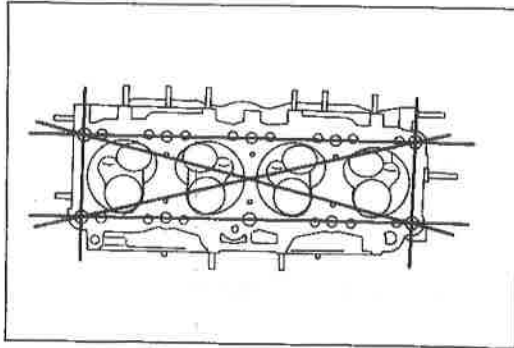

9BU0B1-021

Disassembly of Cylinder Head

Refer to page B1-28.

Inspection of Cylinder Head

Refer to page B1-34.

Assembly of Cylinder Head

Refer to page B1-56.

Installation

Install in the reverse order of removal referring to the **Installation note**.

Caution

After radiator cowling installation, rotate the cooling fan by hand and verify that the fan blade does not touch the radiator cowling.

If the fan touches the cowling, adjust the radiator cowling mounting position.

Note

a) Position the hose clamp in the original location on the hose.

b) Squeeze the clamp lightly with large pliers to ensure a good fit.

Torque Specifications

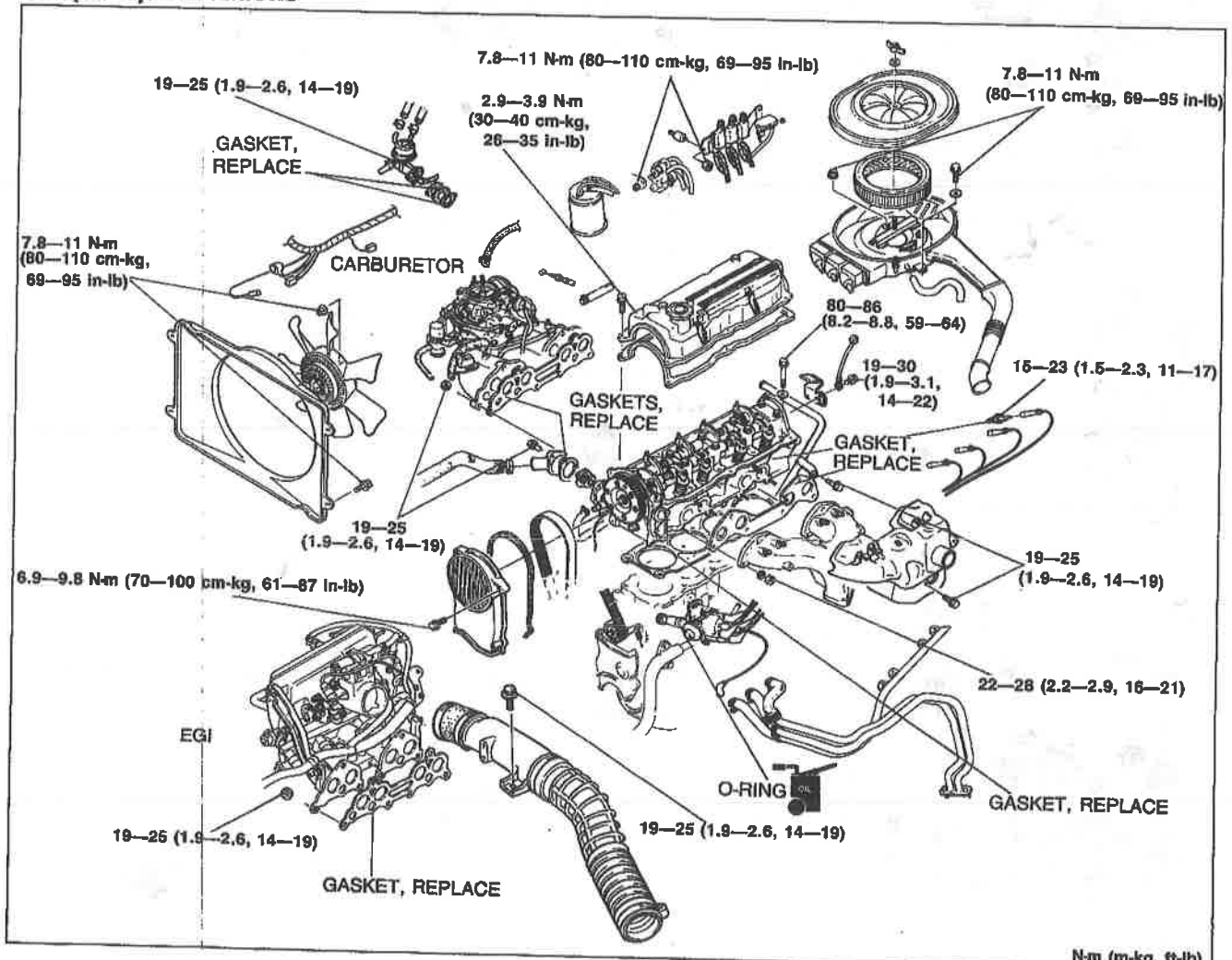

N-m (m-kg, ft-lb)

9BU0B1-092

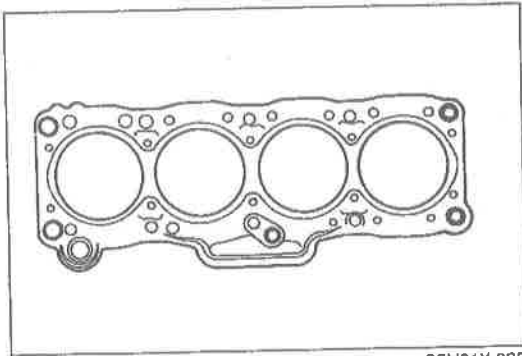

86U01X-035

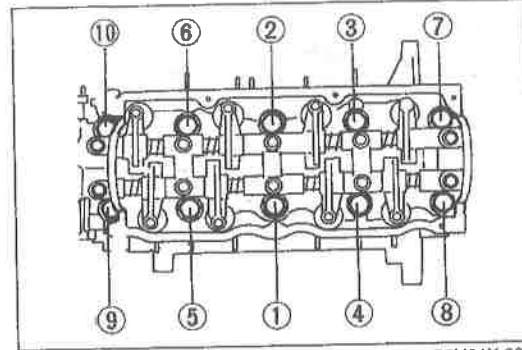

86U01X-036

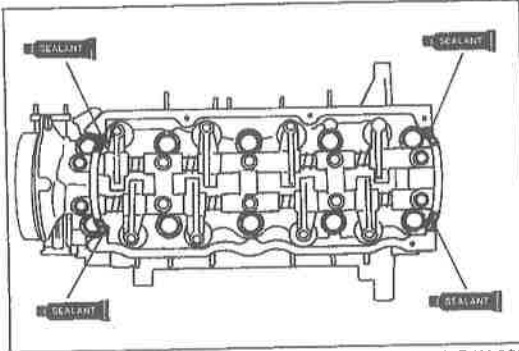

9BU0B1X-022

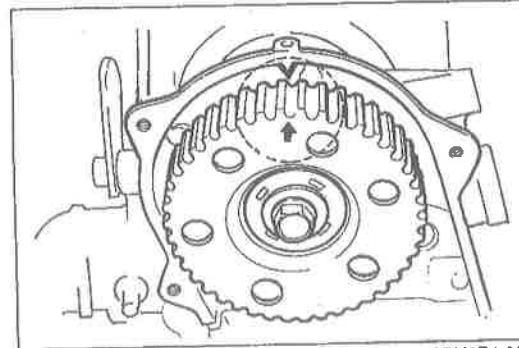

9BU0B1-093

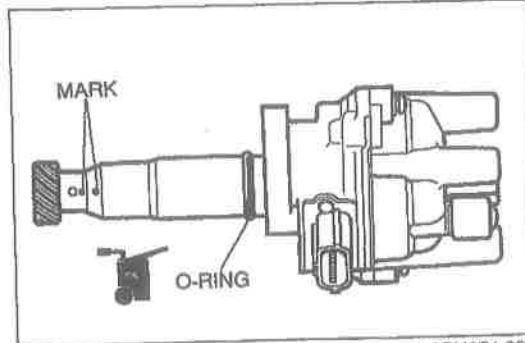

0BU0B1-005

Installation note

Cylinder head

1. Thoroughly remove all dirt and oil from the top of the cylinder block with a rag.
2. Place a new cylinder head gasket in position.

3. Set the cylinder head in place.
4. Apply engine oil to the bolt threads and seat faces.
5. Tighten the cylinder head bolts in two or three steps in the order shown in the figure.

Tightening torque:

80—86 N·m (8.2—8.8 m·kg, 59—64 ft·lb)

Cylinder head cover

1. Apply engine oil to the valves and rocker arms.
2. Apply silicone sealant to the shaded areas shown in the figure.
3. Install the cylinder head cover.

Tightening torque:

2.9—3.9 N·m (30—40 cm·kg, 26—35 in·lb)

Timing belt

1. Align the **↑1** mark of the camshaft pulley with the front housing matching mark.
2. Install the timing belt. (Refer to page B1-10.)

Distributor

1. Apply engine oil to the new O-ring, and position it on the distributor.
2. Apply engine oil to the distributor driven gear.
3. Align the distributor housing and driven gear marks.
4. Install the distributor into the front housing.
5. Loosely tighten the distributor mounting bolt.

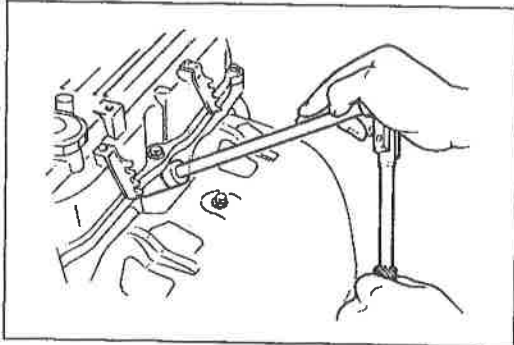

9MU0B2-057

Spark plug

1. Apply anti-seize compound or molybdenum-based lubricant to the spark plug threads.
2. Install the spark plugs.

Tightening torque:

15—23 N·m (1.5—2.3 m·kg, 11—17 ft·lb)

Steps After Installation

1. Add engine coolant to the specified levels.
2. Connect the negative battery cable.
3. Start the engine and do the following:
 - (1) Check for leakage of engine coolant.
 - (2) Perform engine adjustments if necessary.
 - (3) Recheck the oil and coolant levels.

9MU0B2-058

FRONT OIL SEAL

Preparation

SST

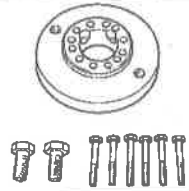
<p>49 S120 710</p> <p>Holder, coupling flange</p> 	<p>49 H011 101A</p> <p>Crankshaft lock tool</p> 
---	---

9BU0B1-115

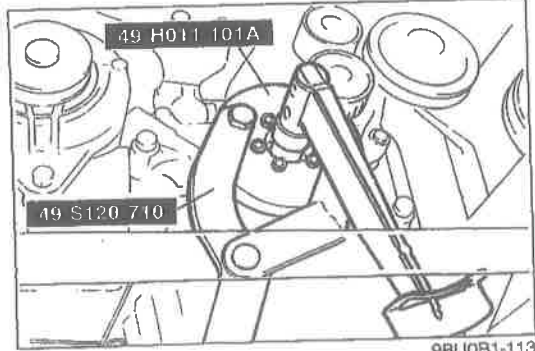
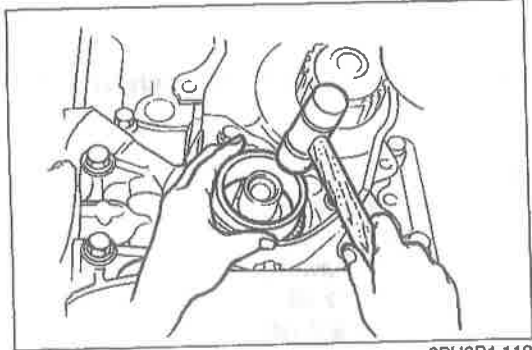
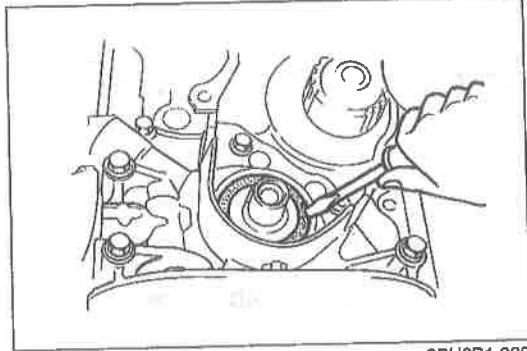
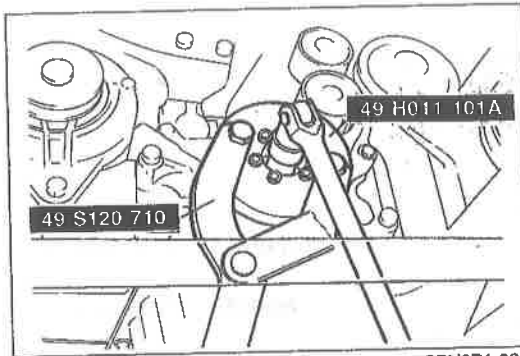

Removal

1. Disconnect the negative battery cable.
2. Drain the engine oil.
3. Remove the timing belt. (Refer to page B1-8.)
4. Remove the timing belt pulley with the **SST**.

5. Remove the oil seal with a screwdriver and a rag.

Installation

Install in the reverse order of removal referring to the **Installation note**.

Installation note Front oil seal

1. Apply engine oil to the new seal lip.
2. Fit the oil seal onto the oil pump body.
3. Tap the oil seal in evenly using a suitable pipe.

Oil seal outer diameter: 48mm (1.89 in)

Caution

The oil seal must be tapped in until it is flush with the edge of the oil pump body.

Timing belt pulley

Install the timing belt pulley with the **SST**.

Tightening torque:

157—167 N·m (16.0—17.0 m·kg, 116—123 ft·lb)

Steps After Installation

1. Add engine oil to the specified levels.
2. Connect the negative battery cable.
3. Start the engine and do the following:
 - (1) Check for leakage of engine oil.
 - (2) Perform engine adjustments if necessary.
 - (3) Recheck the oil levels.

REAR OIL SEAL

Preparation

SST

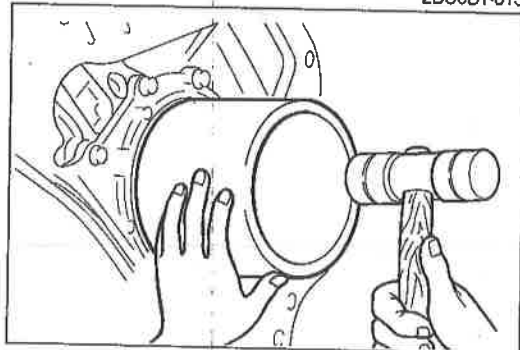
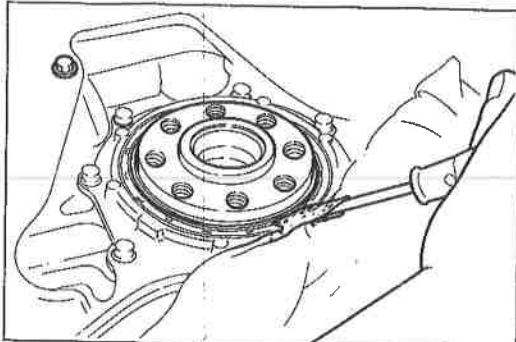
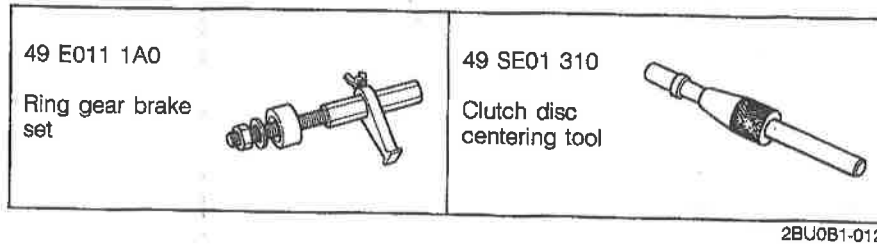

Removal

1. Disconnect the negative battery cable.
2. Drain the engine oil.
3. Remove the manual transmission.
(Refer to Sections J1, J2, J3.)
Remove the automatic transmission.
(Refer to Sections K1, K2, K3.)
4. Remove the clutch cover, clutch disc, and flywheel with the **SST**. (Refer to Section H.)
Remove the plate, drive plate, and adapter with the **SST**.
(Refer to Sections K1, K2, K3.)
5. Remove the oil seal with a screwdriver and a rag.

Installation

Install in the reverse order of removal referring to the **Installation note**.

Installation note

Rear oil seal

1. Apply engine oil to the new oil seal lip.
2. Fit the oil seal onto the rear cover.
3. Tap the oil seal in evenly using a suitable pipe.

Oil seal outer diameter: 110mm (4.33 in)

Caution

The oil seal must be tapped in until it is flush with the edge of the rear cover.

Steps After Installation

1. Add engine oil to the specified levels.
2. Connect the negative battery cable.
3. Start the engine and do the following:
 - (1) Check for leakage of engine oil.
 - (2) Perform engine adjustments if necessary.
 - (3) Recheck the oil levels.

9MU0B2-068

B1

REMOVAL

REMOVAL

PREPARATION SST

49 W023 585A

Adjust wrench



9MU0B2-069

Warning: Release the fuel pressure. (Refer to Sections F1, F2.)

1. Disconnect the negative battery cable.
2. Remove the starter (Refer to Section G) and transmission. (Refer to Sections J1, J2, J3 and K1, K2, K3.)
3. Drain the engine oil and coolant.
4. Remove in the order shown in the figure referring to the **Removal note**.

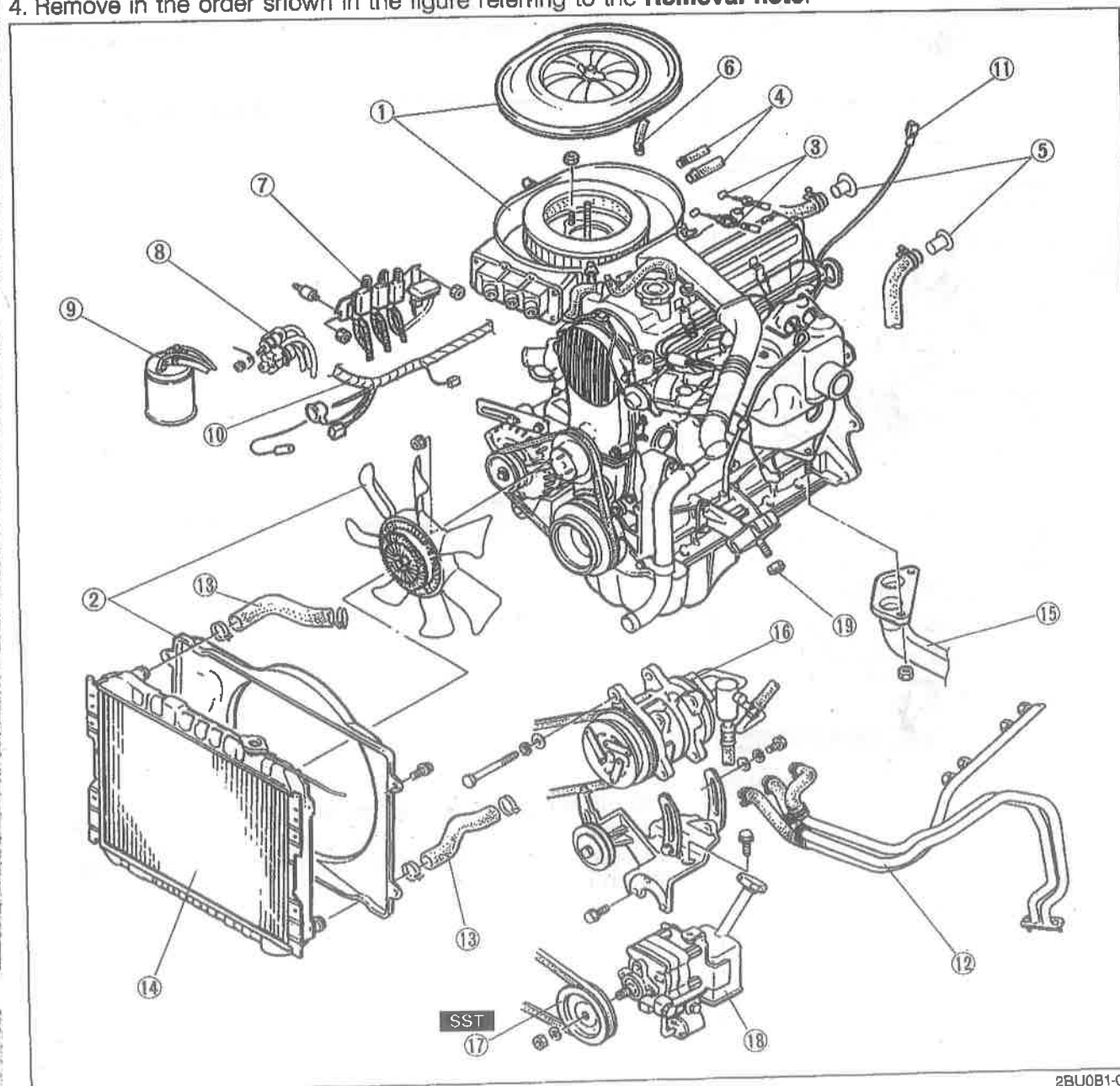

2BU0B1-014

1. Air cleaner assembly
2. Cooling fan and radiator cowl
3. Accelerator cable
4. Fuel hoses
5. Heater hoses
6. Brake vacuum hose
7. Three-way solenoid valve assembly
8. Vacuum solenoid valve assembly
9. Canister hoses
10. Engine harness

11. Engine ground
12. Secondary air pipe assembly (Carburetor)
13. Radiator hoses
14. Radiator
15. Exhaust pipe
16. A/C compressor
17. P/S oil pump pulley
18. P/S oil pump
19. Engine mount nuts

18U0B1-005

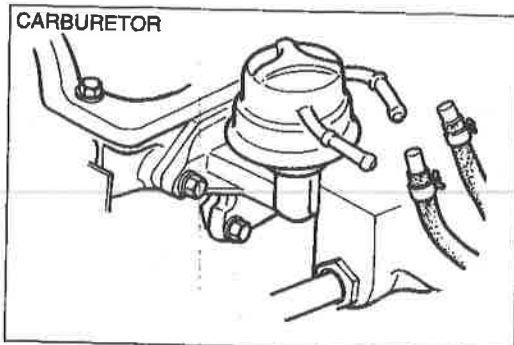

76G01A-118

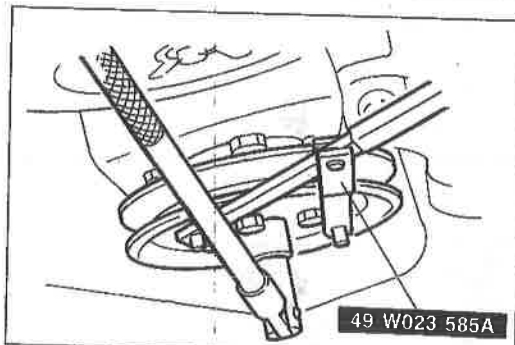
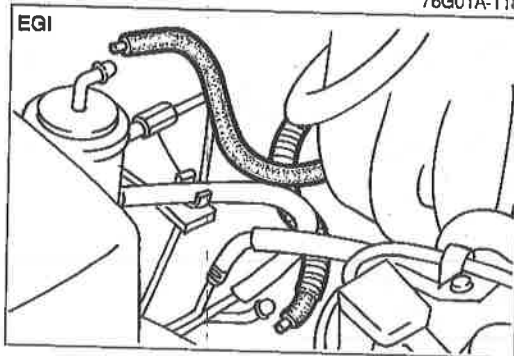

9MU0B2-250

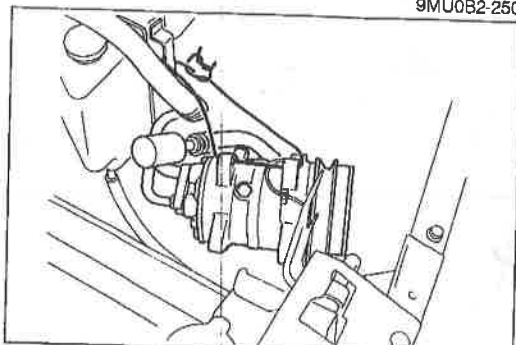

Removal note Fuel hose

Warning

- a) Cover the hose with a rag because fuel will spray out when disconnecting.
- b) Keep sparks and open flame away from the fuel area.

Plug the disconnected hoses to avoid fuel leakage.

P/S oil pump pulley

Remove the P/S oil pump pulley with the SST.

P/S oil pump, A/C compressor







Remove the P/S oil pump and A/C compressor with the hoses still connected to them; secure the pump and compressor as shown in the figure.

B1

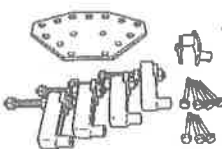
ENGINE STAND INSTALLATION

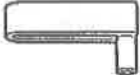
ENGINE STAND INSTALLATION

PREPARATION SST

49 0107 680A Engine stand 	49 L010 1A0 Hanger, engine stand 	49 L010 101 Plate (Part of 49 L010 1A0) 
49 L010 102 Arms (Part of 49 L010 1A0) 	49 L010 103 Hooks (Part of 49 L010 1A0) 	49 L010 104 Nuts (Part of 49 L010 1A0) 
49 L010 105 Bolts (Part of 49 L010 1A0) 	49 L010 106 Bolts (Part of 49 L010 1A0) 	9MU0B2-073

INSTALLATION

1. Remove the parts in the order shown in the figure.
2. Install the engine to the engine stand referring to the **Installation Note**.

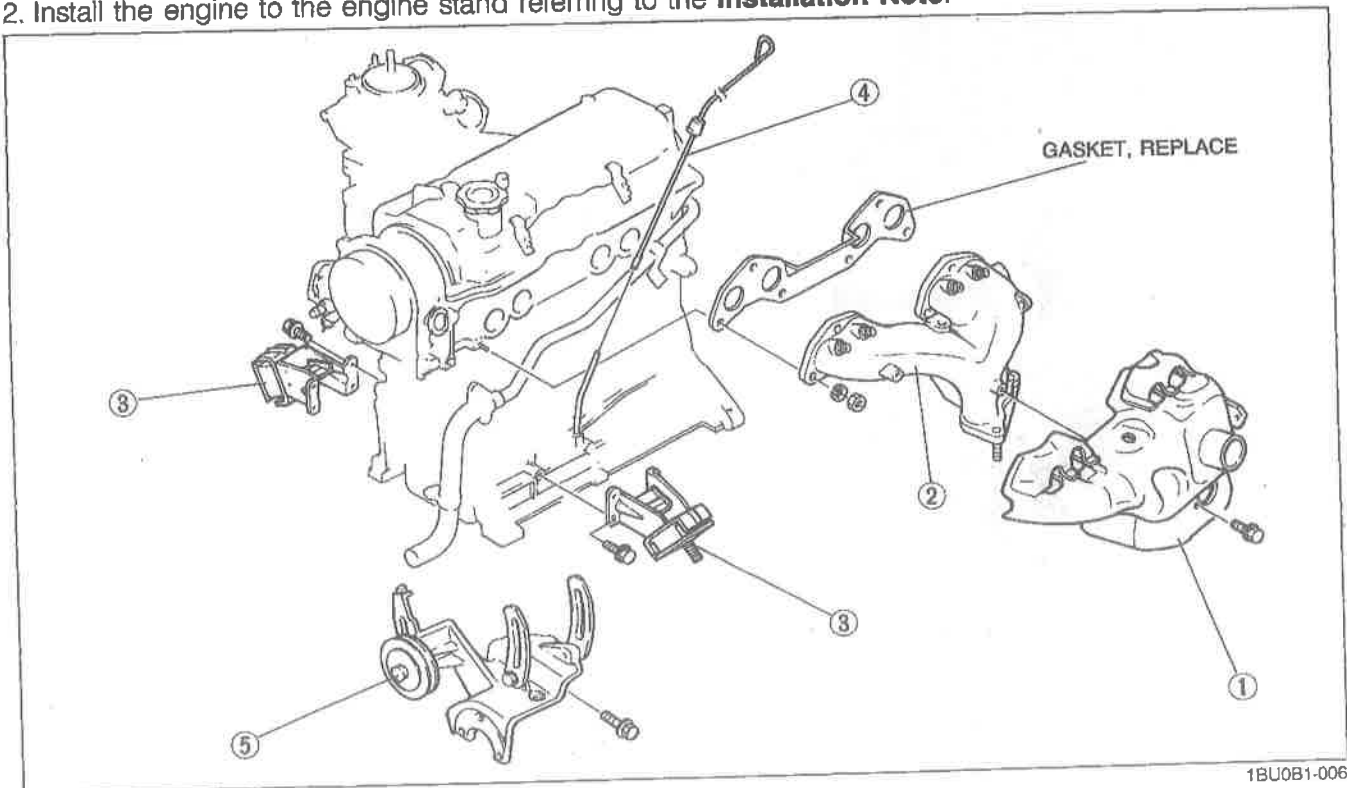

1BU0B1-006

1. Exhaust manifold insulator
2. Exhaust manifold
3. Engine mounts

4. Oil level gauge
5. A/C compressor and P/S oil pump bracket

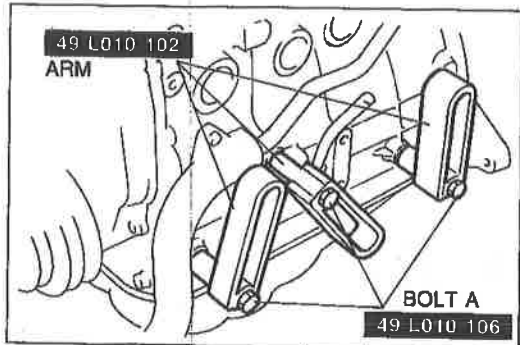

9BU0B1-117

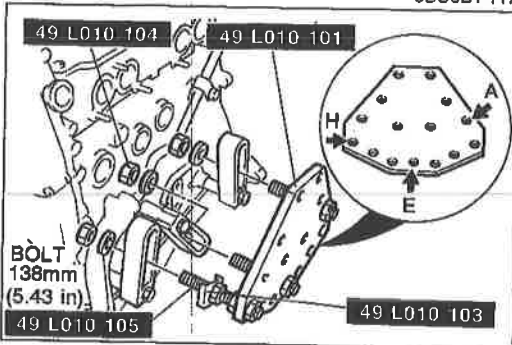

9MU0B2-252

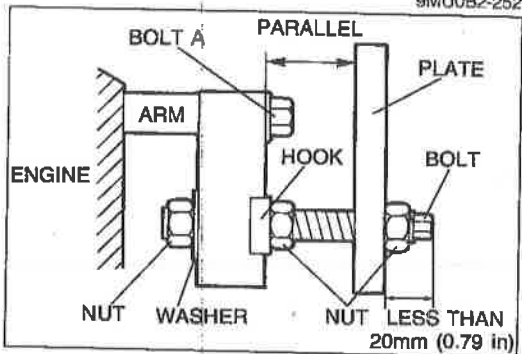

9MU0B2-253

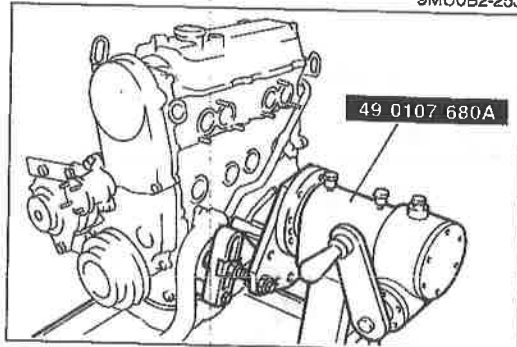

9MU0B2-254

Installation note Engine Hanger

1. Install the **SST (arms)** to the block holes as shown in the figure and loosely tighten **SST (bolts A)**.

2. Assemble the **SST (bolts, nuts, hooks and plate)**.
3. Install the **SST** assembly to the respective arms while adjusting parallelism between the arms and plate by turning the bolts and nuts.

Warning

Use special caution while turning the engine stand handle to prevent hand injury.

4. Tighten the bolts and nuts to fix the **SST**.











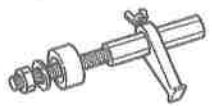

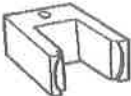
5. Install the engine on the **SST**.

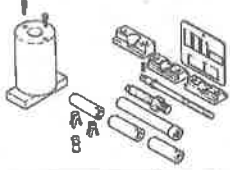
B1

DISASSEMBLY

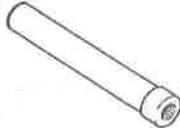
DISASSEMBLY

PREPARATION SST

<p>49 E011 1A0</p> <p>Ring gear brake set</p> 	<p>49 0636 100A</p> <p>Arm, valve spring lifter</p> 	<p>49 G030 222</p> <p>Pivot, valve spring lifter</p> 
<p>49 1285 071</p> <p>Puller, bearing</p> 	<p>49 L011 0A0</p> <p>Piston pin setting tool set</p> 	<p>49 L011 001</p> <p>Support block body (Part of 49 L011 0A0)</p> 
<p>49 L011 003</p> <p>Support block head (Part of 49 L011 0A0)</p> 	<p>49 L011 004</p> <p>Screw (Part of 49 L011 0A0)</p> 	<p>49 L011 006</p> <p>Puller & installer (Part of 49 L011 0A0)</p> 
<p>49 L011 008</p> <p>Guide (Part of 49 L011 0A0)</p> 	<p>49 L011 010</p> <p>Centering tool (Part of 49 L011 0A0)</p> 	<p>49 L011 011</p> <p>Holder (Part of 49 L011 0A0)</p> 

2BU0B1-015

1. Code all identical parts (such as pistons, piston rings, connecting rods, and valve springs) so that they can be reinstalled in the cylinder from which they were removed.
2. Clean the parts with steam; blow off any remaining water with compressed air.

Note
During the disassembly of any part or system, be sure to study its order of assembly. Also, note any deformation, wear, or damage.

9MU0B2-077

AUXILIARY PARTS

Remove in the order shown in the figure.

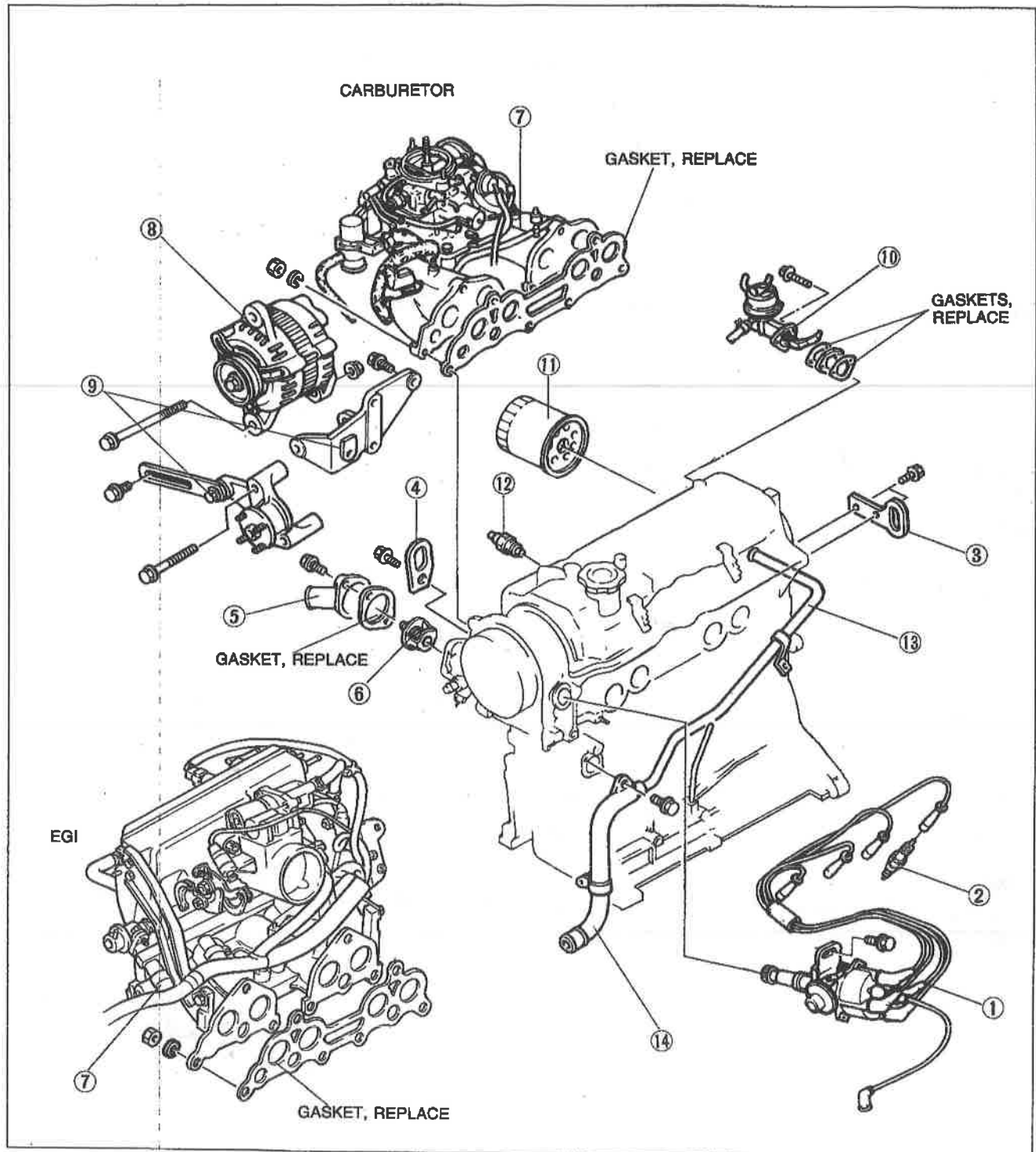

1BU0B1-007

- 1. Distributor and high-tension leads
- 2. Spark plugs
- 3. Rear engine hanger
- 4. Front engine hanger
- 5. Thermostat cover
- 6. Thermostat
- 7. Intake manifold assembly

Service Section E

- 8. Alternator
- 9. Alternator bracket and cooling fan bracket
- 10. Fuel pump (Carburetor M/T)
- 11. Oil filter
- 12. Oil pressure switch
- 13. Coolant bypass pipe
- 14. Coolant inlet pipe

TIMING BELT

1. Remove in the order shown in the figure referring to the **Disassembly note**.
2. Inspect all parts and repair or replace as necessary.

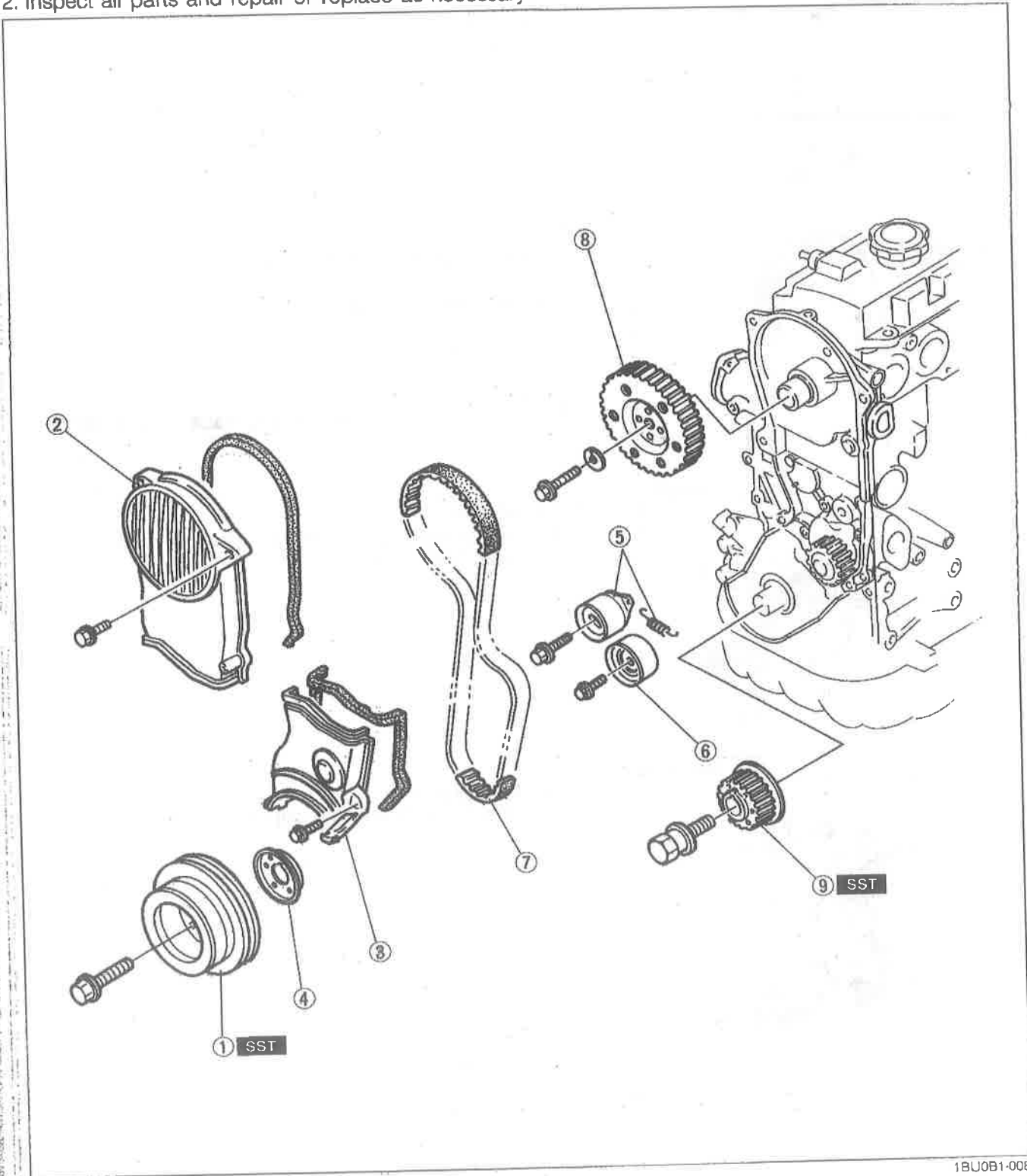

1BU0B1-008

1. Crankshaft pulley
2. Upper timing belt cover
3. Lower timing belt cover
4. Baffle plate
5. Timing belt tensioner and spring

6. Timing belt idler pulley
7. Timing belt
8. Camshaft pulley
9. Timing belt pulley

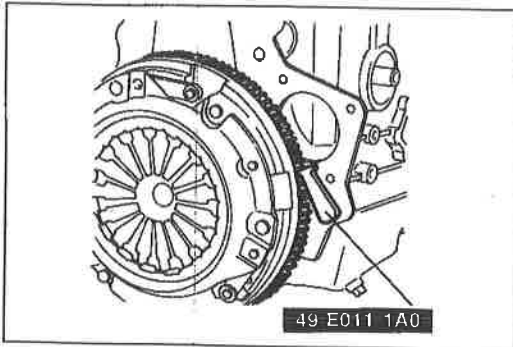

49 E011 1A0

76G01A-121

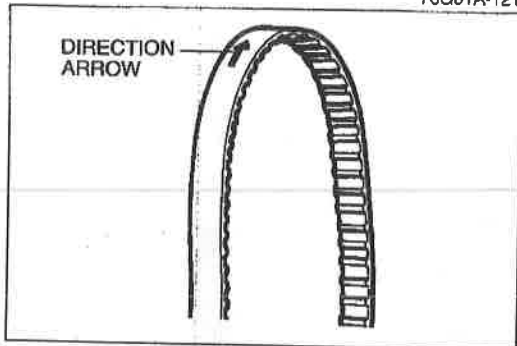

DIRECTION
ARROW

76G01A-122

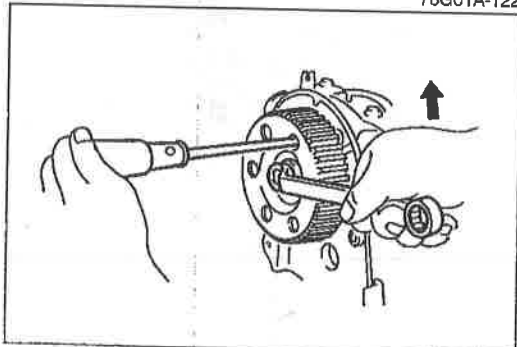

76G01A-123

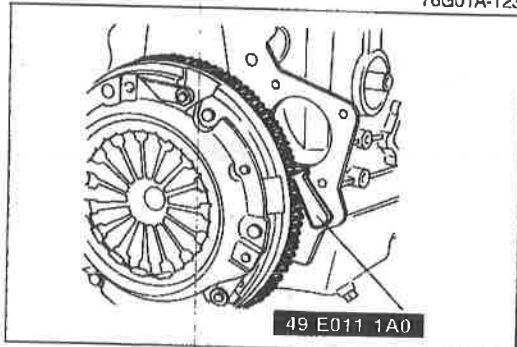

49 E011 1A0

9BU0B1-032

Disassembly note

Crankshaft pulley

1. Set the **SST** against the flywheel.
2. Remove the crankshaft pulley.

Timing belt

1. Loosen the tensioner lock bolt, and remove the tensioner spring.
2. Mark the timing belt rotation for proper reinstallation if it is reused.
3. Remove the timing belt.

Caution

Be careful not to allow oil or grease on the belt.

Camshaft pulley

Remove the pulley lock bolt using a screw driver to prevent the camshaft from turning.

Timing belt pulley

Remove the timing belt pulley with the **SST**.

CYLINDER HEAD

1. Remove in the order shown in the figure referring to the **Disassembly note**.
2. Inspect all parts and repair or replace as necessary.

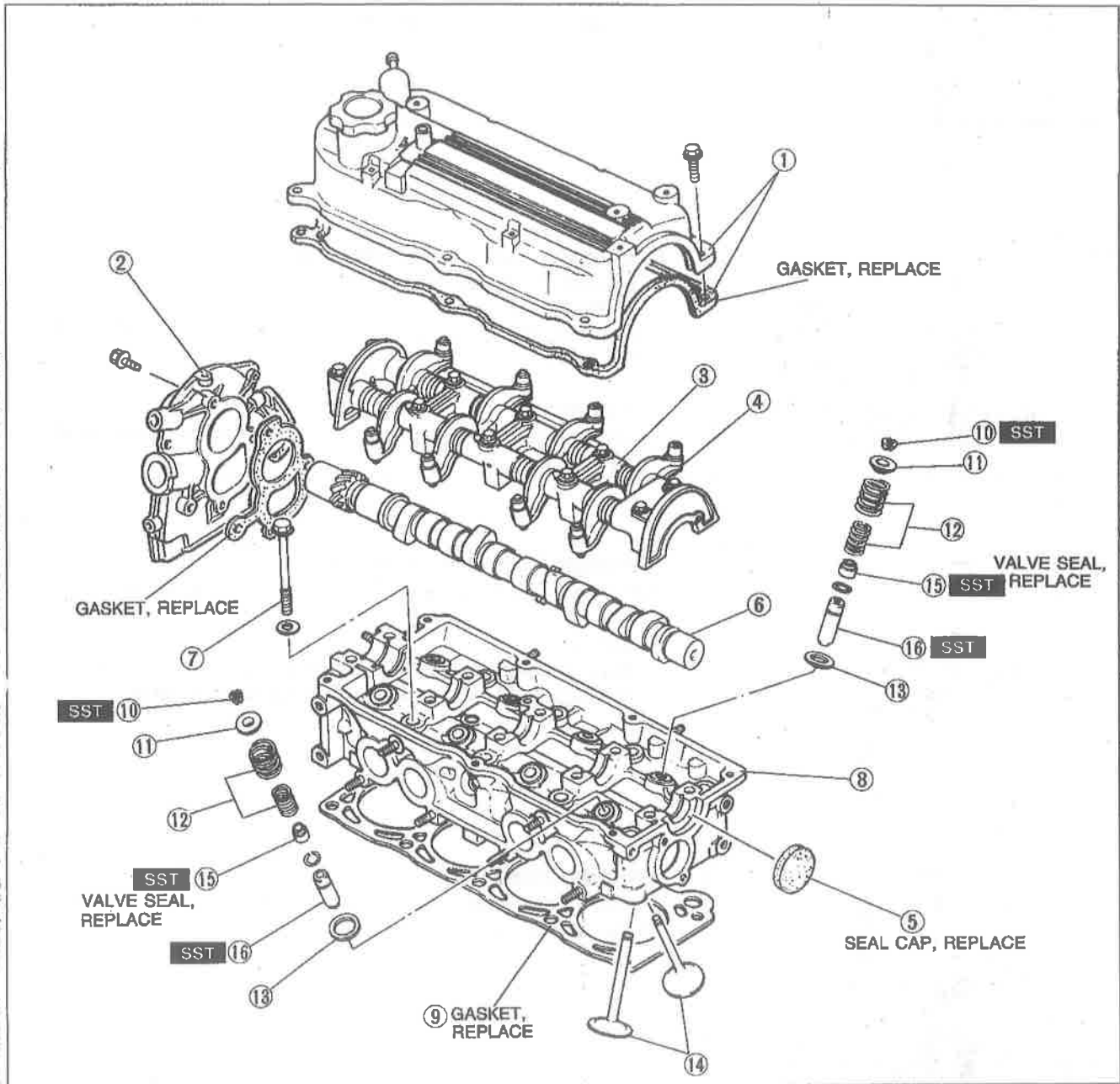

1BU0B1-009

- | | |
|--|--|
| 1. Cylinder head cover and gasket | 9. Cylinder head gasket |
| 2. Front housing | 10. Valve keepers |
| 3. Rocker arm and shaft assembly
Inspection..... page B1-40 | 11. Upper spring seat |
| 4. Hydraulic lash adjuster (HLA)
Inspection..... page B1-40 | 12. Valve spring, outer and inner
Inspection..... page B1-38 |
| 5. Seal cap | 13. Lower spring seat |
| 6. Camshaft
Inspection..... page B1-39 | 14. Valve
Inspection..... page B1-35 |
| 7. Cylinder head bolt | 15. Valve seal
Inspect for wear or damage |
| 8. Cylinder head
Inspection..... page B1-34 | 16. Valve guide
Inspection..... page B1-35
Replacement..... page B1-36 |

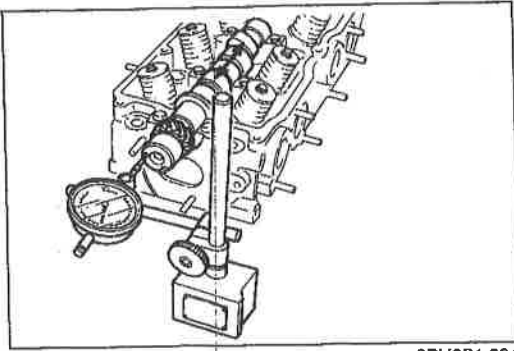

9BU0B1-034

Disassembly note

During disassembly, inspect the following.

1. Camshaft end play (Refer to page B1-40.)
2. Camshaft journal oil clearance (Refer to page B1-39.)

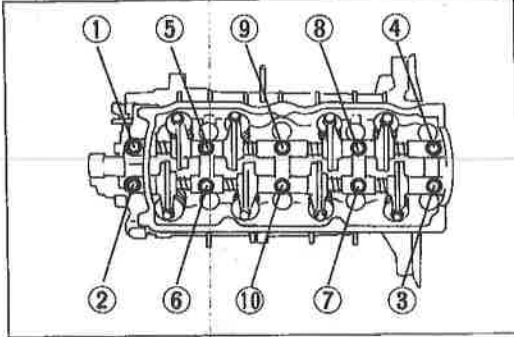

9MU0B2-081

Rocker arm and shaft assembly

1. Loosen the bolts in two or three steps in the order shown in the figure.
2. Remove the rocker arm and shaft assembly together with the bolts.

Caution

Do not mix up the parts of the rocker arm and shaft assembly.

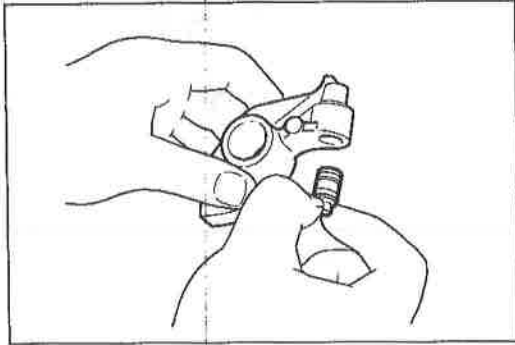

9MU0B2-082

Hydraulic lash adjuster (HLA)

Remove the HLA by hand. If this is difficult, remove it with pliers.

Caution

Do not remove the HLA unless necessary because oil leakage will occur if the O-ring is damaged.

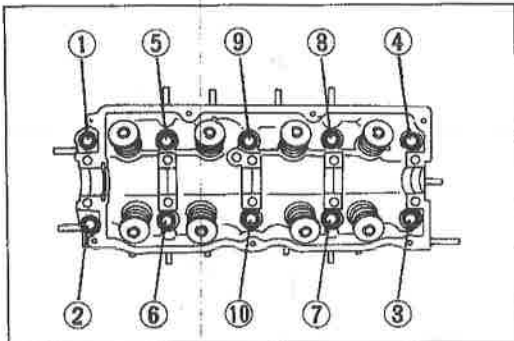

9BU0B1-035

Cylinder head bolt

Loosen the cylinder head bolts in two or three steps in the order shown in the figure.

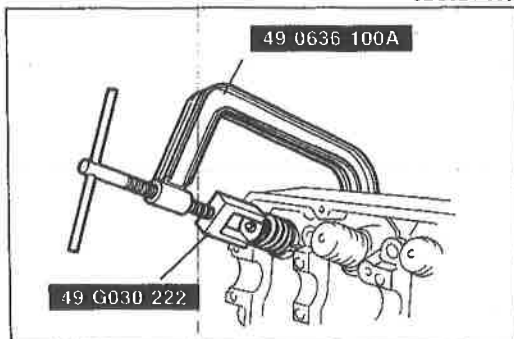

9BU0B2-085

Valve

Remove the valves from the cylinder head with the **SST**.

B1

DISASSEMBLY (CYLINDER BLOCK)

CYLINDER BLOCK I

1. Remove in the order shown in the figure referring to the **Disassembly note**.
2. Inspect all parts and repair or replace as necessary.

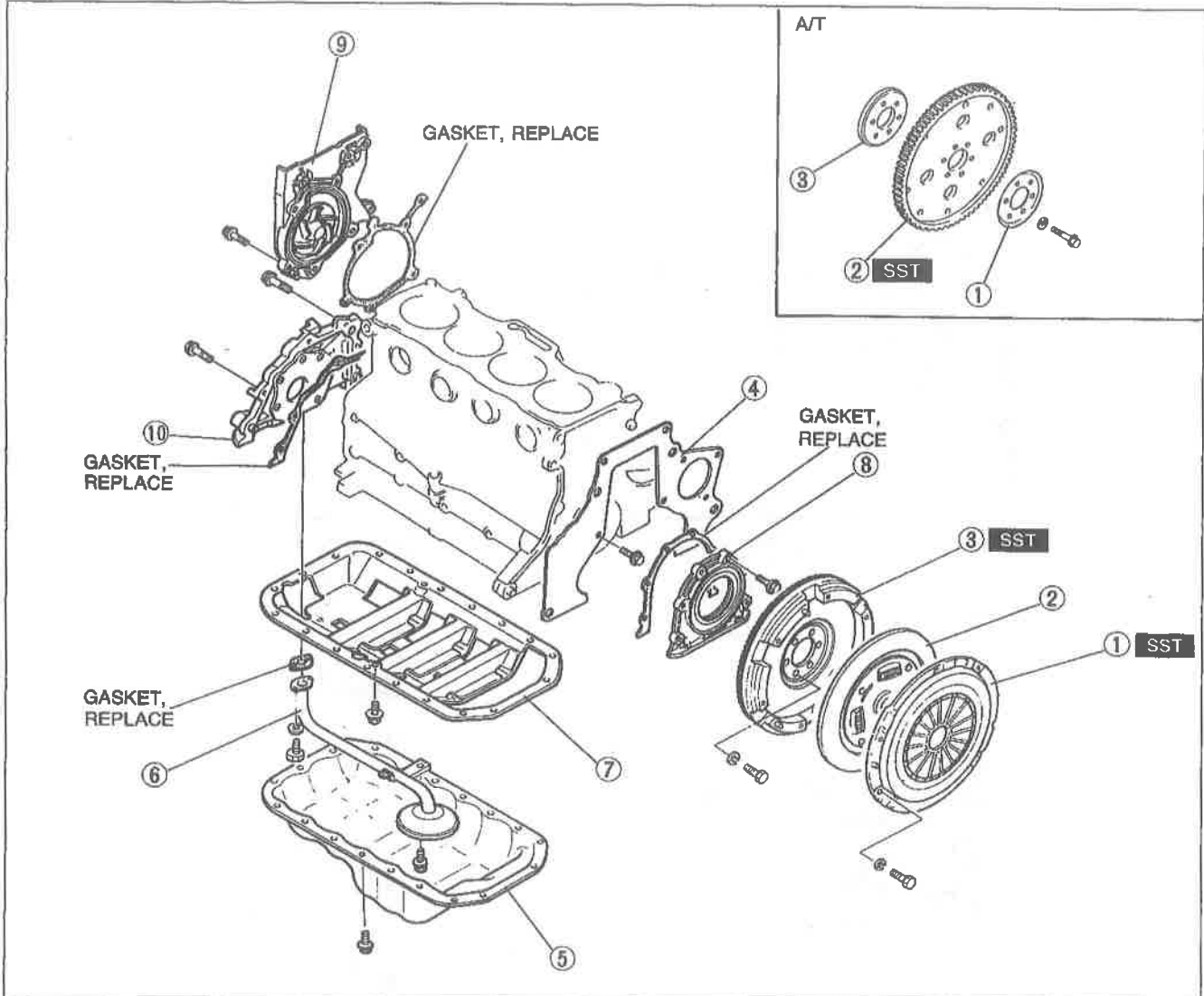

1BU0B1-010

1. Clutch cover (M/T), Backing plate (A/T)
2. Clutch disc (M/T), Drive plate (A/T)
3. Flywheel (M/T), Adapter (A/T)
4. End plate
5. Oil pan
Inspect for damage

6. Oil strainer
7. Stiffener
8. Rear cover
9. Water pump assembly
Service Section E
10. Oil pump assembly
Service Section D

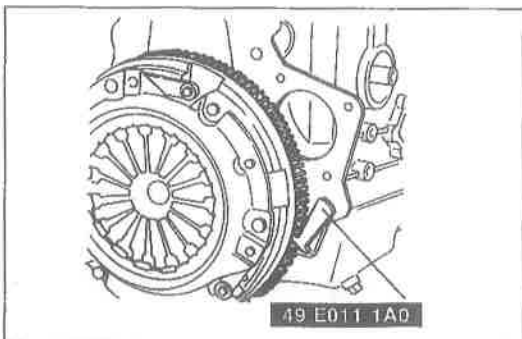

76G01A-125

Disassembly note

Clutch cover, flywheel (M/T) or drive plate (A/T)

Remove the clutch cover and flywheel (M/T), or drive plate (A/T) with the **SST**.

CYLINDER BLOCK II

1. Remove in the order shown in the figure referring to **Disassembly note**.
2. Inspect all parts and repair or replace as necessary.

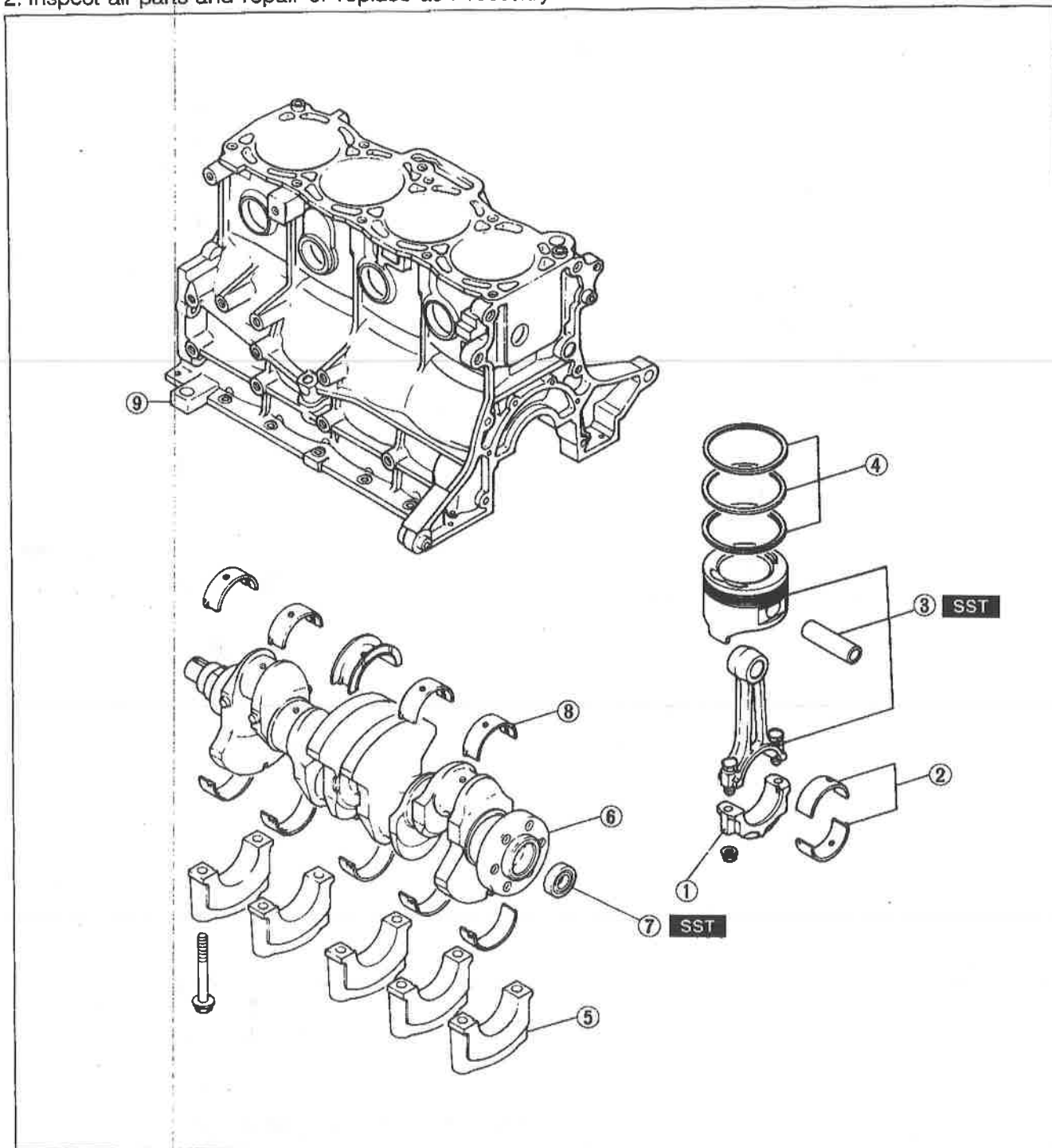

1BU0B1-011

- | | |
|---|--|
| <ol style="list-style-type: none"> 1. Connecting rod cap 2. Connecting rod bearing
Inspect for peeling, scoring, or damage 3. Connecting rod, piston and piston pin
Inspection..... pages B1-42, 43 4. Piston ring
Inspection..... page B1-42 | <ol style="list-style-type: none"> 5. Main bearing cap 6. Crankshaft
Inspection..... page B1-43 7. Pilot bearing (M/T) 8. Main bearing
Inspect for peeling, scoring, or damage 9. Cylinder block
Inspection..... page B1-40 |
|---|--|

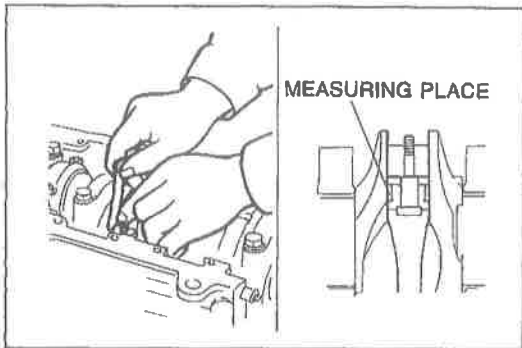

9BU0B1-038

Disassembly note

Connecting rod and cap

Before removing the connecting rod, clean the bearing, connecting rod, and crankpin, and measure the following:

1. Connecting rod side clearance (Refer to page B1-51.)
2. Crankpin oil clearance (Refer to page B1-51.)

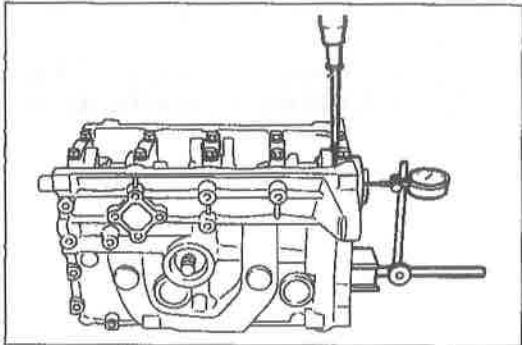

1BU0B1-013

Main bearing cap

Before removing the main bearing caps, clean the bearings, main journals, and caps, and measure the following points.

1. Crankshaft end play (Refer to page B1-50.)
2. Main journal oil clearance (Refer to page B1-49.)

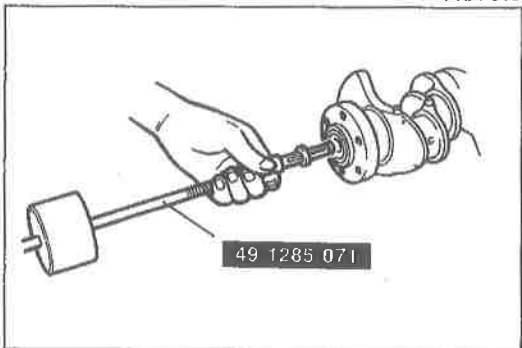

9BU0B1-040

Pilot bearing (M/T)

1. Before removing the pilot bearing, inspect for sticks or excessive resistance by turning the bearing while applying force in the axial direction.
2. Remove the pilot bearing from the crankshaft with the **SST** if necessary.

Note

When replacing and/or cleaning the crankshaft, remove the pilot bearing.

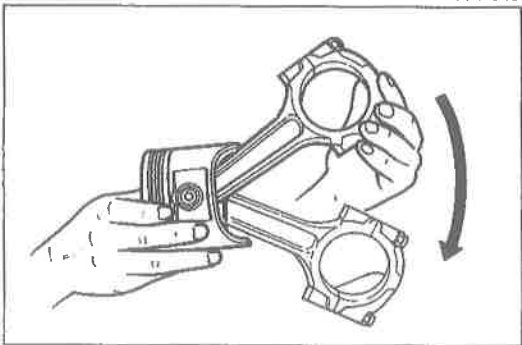

9MU0B2-097

Piston and connecting rod

1. Before disassembling the piston and connecting rod, check the oscillation torque as shown. If the large end does not drop by its own weight, replace the piston or the piston pin.

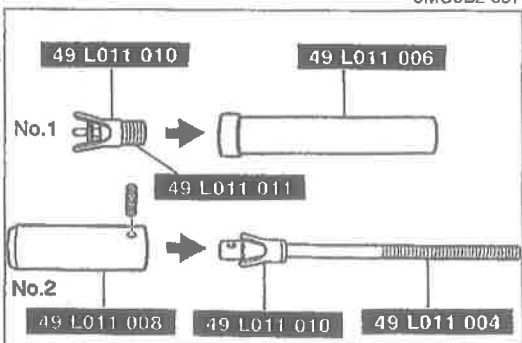

9MU0B2-098

2. Assemble the **SST** as shown.

DISASSEMBLY (CYLINDER BLOCK)

B1

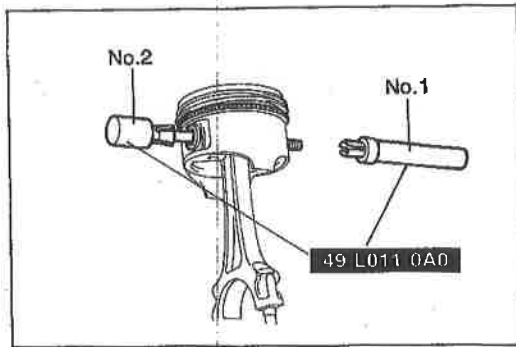

9MU0B2-099

3. Insert the **SST No.2** into the piston pin as shown and fully screw in the **SST No.1**.

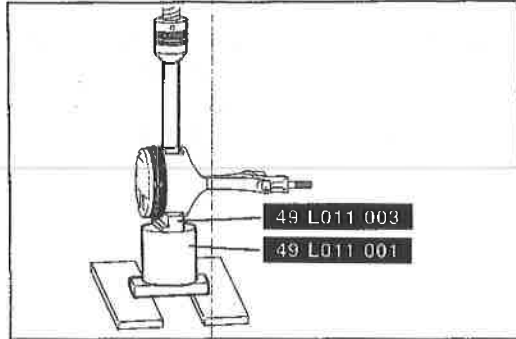



9MU0B2-100

4. Mount the piston and connecting rod in the **SST** as shown.
5. Press out the piston pin.
While removing the piston pin, check the pressure. If it is lower than **4,905 N (500 kg, 1,100 lb)**, replace the piston pin or connecting rod.

INSPECTION AND REPAIR

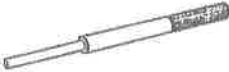
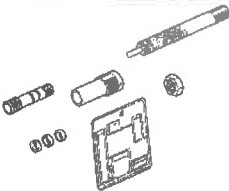
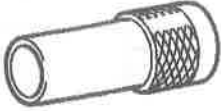
PREPARATION SST

<p>49 0221 251A</p> <p>Remover & installer, valve guide</p> 	<p>49 L012 0A0</p> <p>Installer set, valve seal & valve guide</p> 	<p>49 L012 002</p> <p>Body (Part of 49 L012 0A0)</p> 
<p>49 L012 003</p> <p>Installer (Part of 49 L012 0A0)</p> 	<p>49 L012 004</p> <p>Nut (Part of 49 L012 0A0)</p> 	<p>9MU0B2-101</p>

1. Clean all parts, being sure to remove any gasket fragments, dirt, oil or grease, carbon, moisture residue, or other foreign materials.
2. Inspection and repairs must be performed in the order specified.

Caution

Do not damage the joints or friction surfaces of aluminum alloy components (such as the cylinder head or pistons).

9MU0B2-102

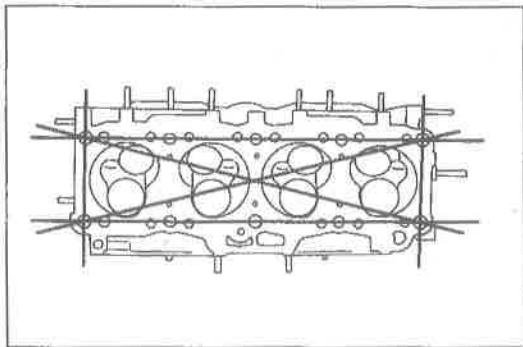

9MU0B2-103

Cylinder Head

1. Inspect the cylinder head for damage, cracks, and leakage of water or oil. Replace if necessary.
2. Measure the cylinder head distortion in the six directions shown in the figure.

Distortion: 0.15mm (0.006 in) max.

3. If the cylinder head distortion exceeds specification, grind the cylinder head surface.
If the cylinder head height is not within specification, replace it.

Height: 91.95—92.05mm (3.620—3.624 in)
Grinding: 0.20mm (0.008 in) max.

Note

Before grinding the cylinder head, first check the following. Replace if necessary.

- Sinking of valve seat
- Damage of manifold contact surface
- Camshaft oil clearance and end play

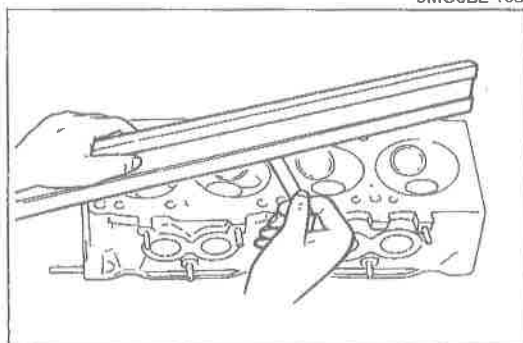

9BU0B1-041

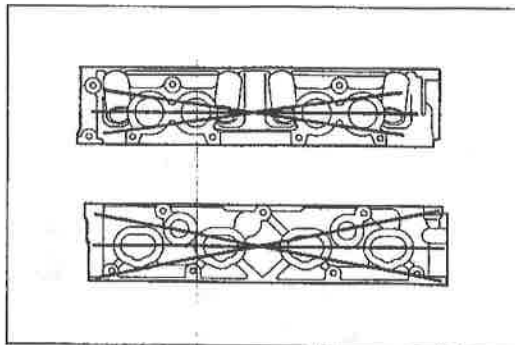

9MU0B2-105

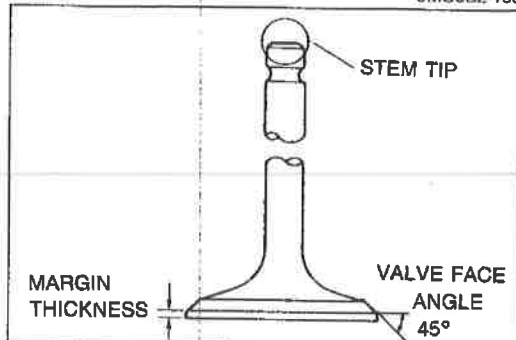

9BU0B1-042

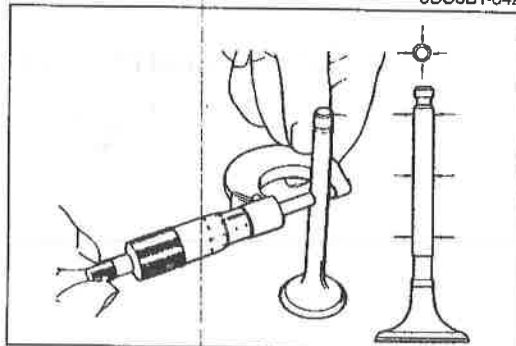

9BU0B1-043

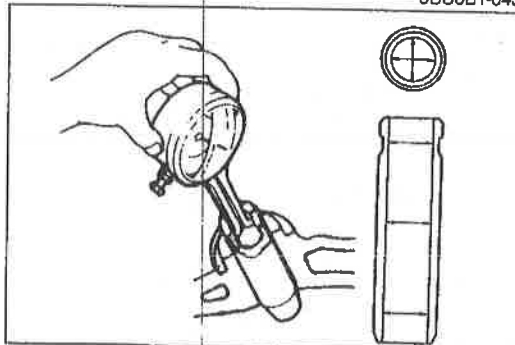

9BU0B1-044

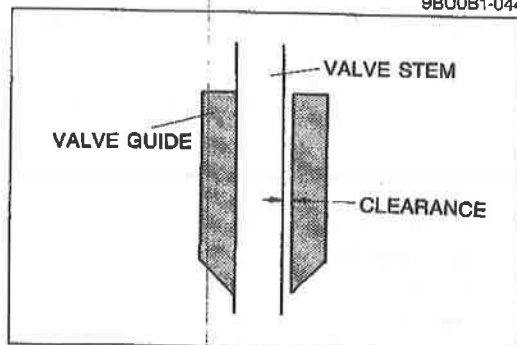

86U01X-081

4. Measure the manifold contact surface distortion in the six directions shown in the figure.

Distortion: 0.15mm (0.006 in) max.

5. If distortion exceeds specification, grind the surface or replace the cylinder head.

Valve and Valve Guide

1. Inspect each valve for the following. Replace or resurface if necessary.
 - (1) Damaged or bent stem
 - (2) Roughness or damage to face
 - (3) Damage or uneven wear of stem tip
2. Check the valve head margin thickness. Replace if necessary.

Margin thickness

IN : 0.5mm (0.020 in) min.

EX : 1.0mm (0.039 in) min.

3. Measure the valve length.

Length

Standard IN : 111.89mm (4.4051 in)

EX : 111.69mm (4.3972 in)

Minimum IN : 111.49mm (4.3894 in)

EX : 111.29mm (4.3815 in)

4. Measure the valve stem diameter.

Diameter

IN : 8.030—8.045mm (0.3161—0.3167 in)

EX : 8.025—8.040mm (0.3159—0.3165 in)

5. Measure the valve guide inner diameter.

Inner diameter

IN : 8.07—8.09mm (0.3177—0.3185 in)

EX : 8.07—8.09mm (0.3177—0.3185 in)

6. Measure the valve stem-to-guide clearance.

(1) Method No.1

Subtract the outer diameter of the valve stem from the inner diameter of the corresponding valve guide.

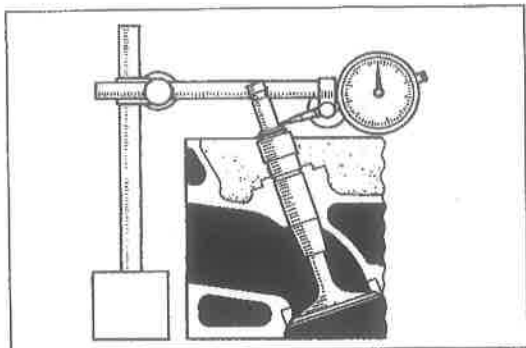

9MU0B2-109

(2) Method No.2

Measure the valve stem play at a point close to the valve guide with the valve lifted slightly off the valve seat.

Clearance

IN : 0.025—0.060mm (0.0010—0.0024 in)

EX: 0.030—0.065mm (0.0012—0.0026 in)

Maximum: 0.20mm (0.008 in)

7. If the clearance exceeds the maximum, replace the valve and/or valve guide.

8. Check the valve guide projection height (dimension A in the figure). Replace if necessary.

Height: 19.1—19.6mm (0.752—0.772 in)

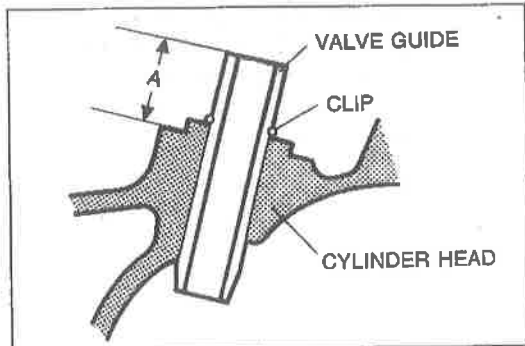

9BU0B1-046

Replacement of valve guide

Note

Although the shapes of the intake and exhaust valve guides are different, use the exhaust valve guide on both sides as a replacement.

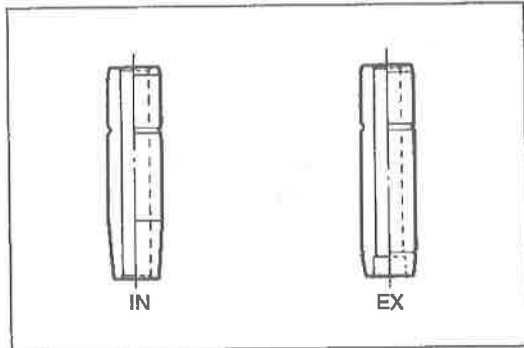

9MU0B2-111

Removal

Remove the valve guide from the side opposite the combustion chamber with the **SST**.

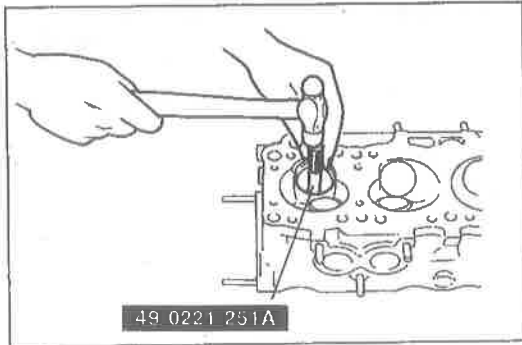

9MU0B2-112

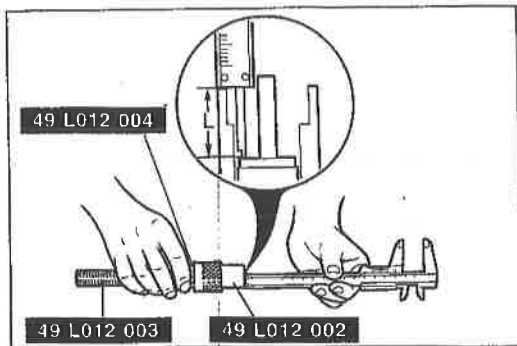

9BU0B1-046

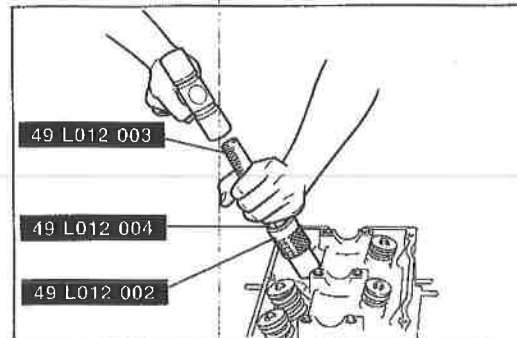

0BU0B1-020

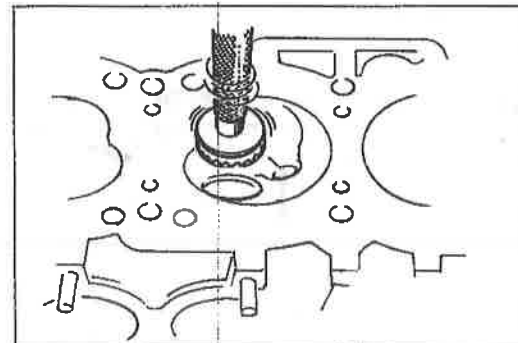

86U01X-087

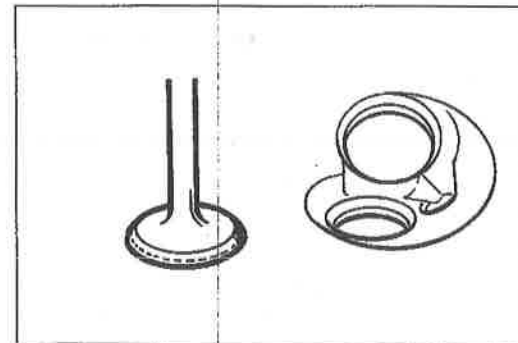

9MU0B2-255

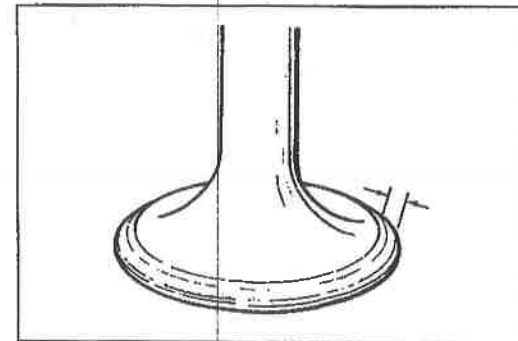

79G01C-062

Installation

1. Assemble the **SST** so that the depth **L** is as specified.

Depth L: 19.1—19.6mm (0.752—0.772 in)

2. Tighten the locknut.

3. Tap a new valve guide in from the side opposite the combustion chamber until the **SST** contacts the cylinder head.
4. Check that the valve guide projection height is within specification.
5. If not within specification, repeat steps 1—4.

Valve Seat

1. Inspect the contact surface of the valve seat and valve face for the following:
 - (1) Roughness
 - (2) Damage
2. If necessary, resurface the valve seat with a **45°** valve seat cutter and/or resurface the valve face.

3. Apply a thin coat of Prussian blue to the valve face.
4. Check the valve seating by pressing the valve against the seat:
 - (1) If blue does not appear 360° around the valve face, replace the valve.
 - (2) If blue does not appear 360° around the valve seat, resurface the seat.

5. Check the seat contact width.

Width: 1.2—1.6mm (0.047—0.063 in)

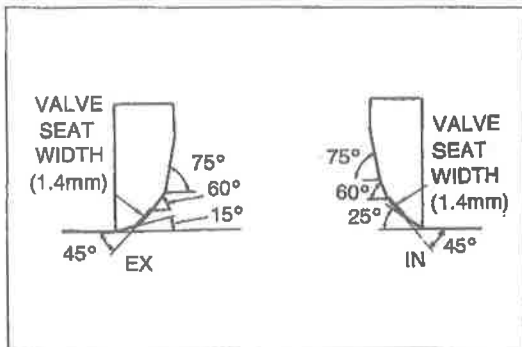

9BU0B1-047

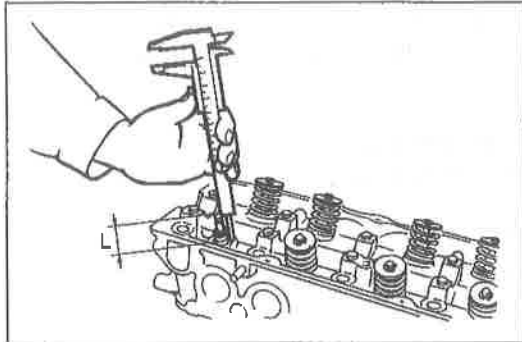

9BU0B1-048

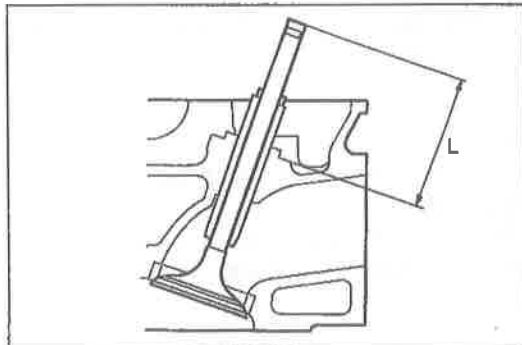

9BU0B1-049

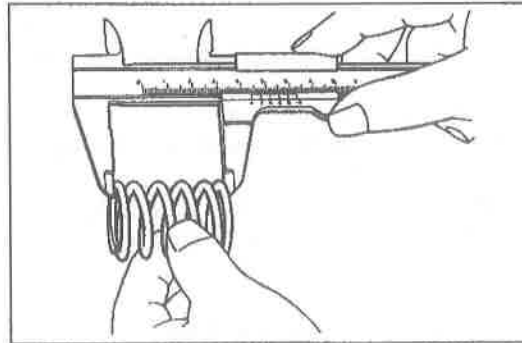

9BU0B1-050

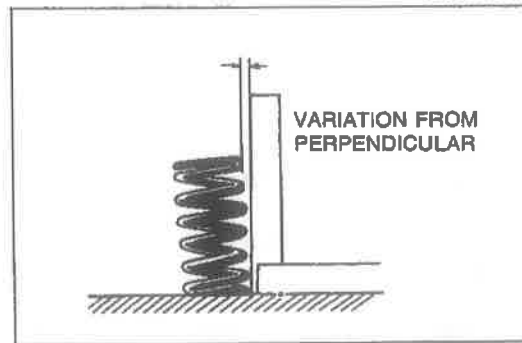

9BU0B1-051

6. Check that the valve seating position is at the center of the valve face.

- (1) If the valve seating position is too high, correct the valve seat with a **60°** cutter.
- (2) If the valve seating position is too low, correct the valve seat with a **25° (IN)** or **15° (EX)** cutter.

7. Seat the valve to the valve seat with a lapping compound.

8. Check the sinking of the valve seat.

Measure protruding length (dimension L) of each valve stem.

Dimension L

IN : 46.5mm (1.831 in)

EX : 46.5mm (1.831 in)

- (1) If L is as below, it can be used as it is.

IN : 46.5—47.0mm (1.831—1.850 in)

EX : 46.5—47.0mm (1.831—1.850 in)

- (2) If L is as below, insert a spacer between the spring seat and cylinder head to adjust.

IN : 47.0—48.0mm (1.850—1.890 in)

EX : 47.0—48.0mm (1.850—1.890 in)

- (3) If L is more than as below, replace the cylinder head.

IN : 48.0mm (1.890 in)

EX : 48.0mm (1.890 in)

Valve Spring

1. Inspect each valve spring for cracks or damage.

2. Check the free length and out of square. Replace if necessary.

Free length

Standard Outer: 52.0mm (2.047 in)

Inner: 44.0mm (1.732 in)

Minimum Outer: 50.4mm (1.984 in)

Inner: 42.7mm (1.681 in)

Out of square

Outer: 1.8mm (0.07 in) max.

Inner: 1.5mm (0.06 in) max.

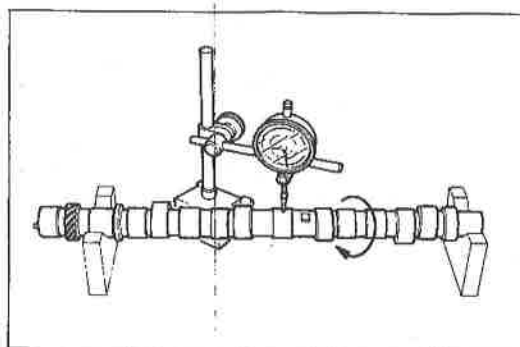

88U01X-092

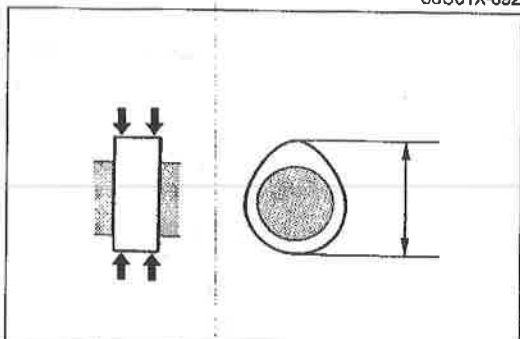

9BU0B1-052

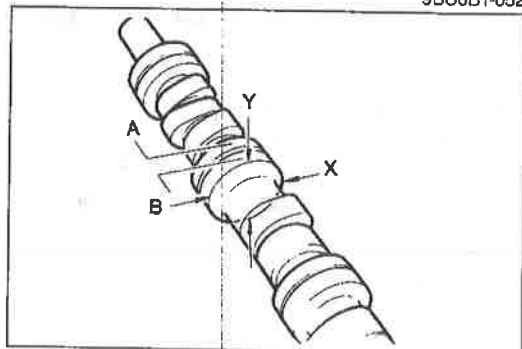

2BU0B1-017

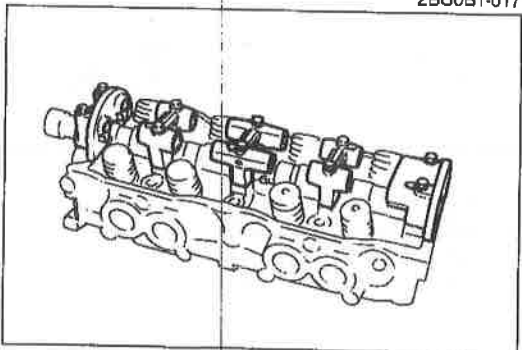

0BU0B1-021

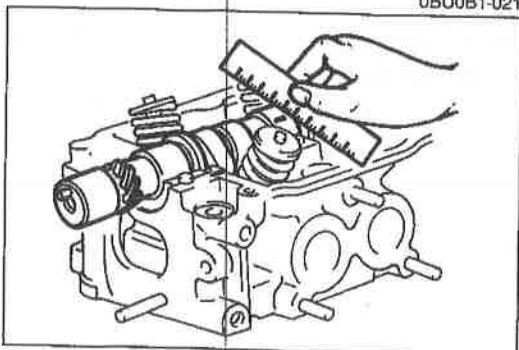

9MU0B2-121

Camshaft

1. Set the front and rear journals on V-blocks. Check the camshaft runout. Replace if necessary.

Runout: 0.03mm (0.0012 in) max.

2. Check the cam for wear or damage. Replace if necessary.
3. Check the cam lobe height at the two points as shown.

Height

IN : 38.059mm (1.4984 in)

EX: 38.059mm (1.4984 in)

Minimum

IN : 37.859mm (1.4905 in)

EX: 37.859mm (1.4905 in)

4. Measure the journal diameters in X and Y directions at the two points (A and B) as shown.

Diameter

No.1 and No.5:

31.940—31.965mm (1.2575—1.2584 in)

No.2, No.3 and No.4:

31.910—31.935mm (1.2563—1.2573 in)

Out-of-round: 0.05mm (0.002 in) max.

5. Measure the oil clearance of the camshaft and camshaft caps.

- (1) Remove any oil, or dirt from the journals and bearing surface.
- (2) Set the camshaft on the cylinder head.
- (3) Position the Plastigauge on top of the journals in the axial direction.
- (4) Place the camshaft caps and rocker arm shafts in position; then tighten them to the specified torque.

Tightening torque:

18—26 N·m (1.8—2.7 m·kg, 13—20 ft·lb)

- (5) Remove the camshaft caps and measure the oil clearance at each cap.

Oil clearance

No.1 and No.5:

0.035—0.085mm (0.0014—0.0033 in)

No.2, No.3 and No.4:

0.065—0.115mm (0.0026—0.0045 in)

Maximum: 0.15mm (0.006 in)

- (6) If the oil clearance exceeds the maximum, replace the cylinder head.

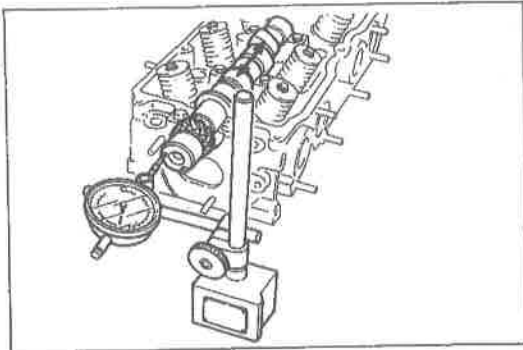

9BU0B1-064

6. Measure the camshaft end play. If it exceeds the maximum, replace the camshaft or the cylinder head.

End play: 0.08—0.16mm (0.0031—0.0063 in)
Maximum: 0.20mm (0.008 in)

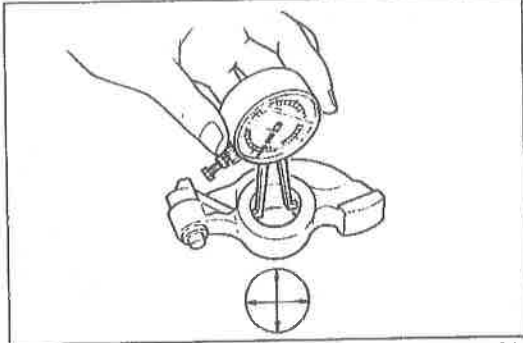

9BU0B1-065

Rocker Arm and Rocker Arm Shaft

1. Check for wear or damage to the contact surfaces of the rocker arm shaft and the rocker arm. Replace if necessary.
2. Check the oil clearance between the rocker arm and shaft. Replace if necessary.
 - (1) Measure the rocker arm inner diameter.

Diameter: 16.000—16.027mm (0.6300—0.6310 in)

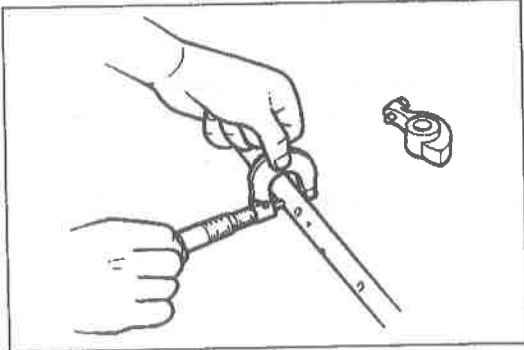

9BU0B1-058

- (2) Measure the rocker arm shaft diameter.

Diameter: 15.966—15.984mm (0.6286—0.6293 in)

- (3) Subtract the shaft diameter from the rocker arm diameter.

Oil clearance: 0.016—0.061mm (0.0006—0.0024 in)
Maximum: 0.10mm (0.004 in)

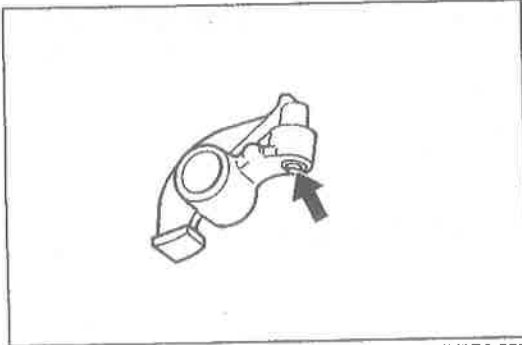

9MU0B2-258

Hydraulic Lash Adjuster (HLA)

Check the HLA face for wear or damage. Replace if necessary.

Caution

Do not remove the HLA unless necessary because oil leakage will occur if the O-ring is damaged.

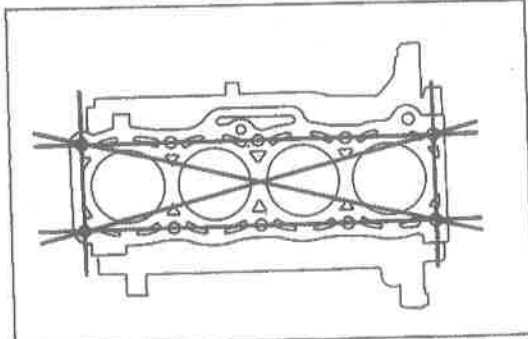

86U01X-100

Cylinder Block

1. Check the cylinder block. Repair or replace if necessary.
 - (1) Leakage damage
 - (2) Cracks
 - (3) Scoring of wall
2. Measure the distortion of the top surface of the cylinder block in the six directions as shown in the figure.

Distortion: 0.15mm (0.006 in) max.

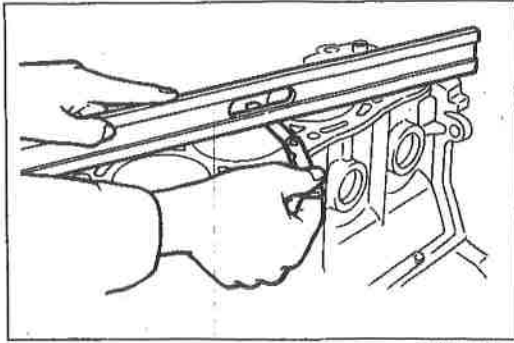

9BU0B1-095

3. If the distortion exceeds the maximum, repair by grinding, or replace the cylinder block.

Height: 301.5mm (11.87 in)
Grinding: 0.20mm (0.008 in) max.

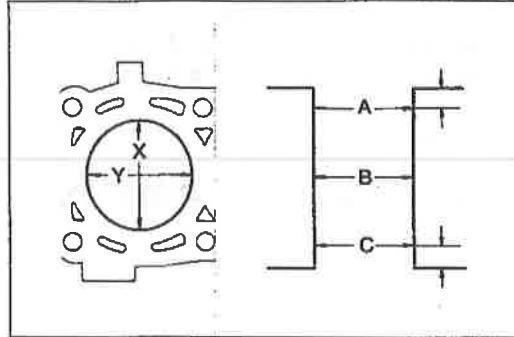

9BU0B1-057

4. Measure the cylinder bore in X and Y directions at three levels (A, B, and C) in each cylinder as shown.

Cylinder bore

mm (in)

Size	Bore	Diameter
Standard		86.000—86.019 (3.3858—3.3866)
0.25 (0.010) oversize		86.250—86.269 (3.3957—3.3964)
0.50 (0.020) oversize		86.500—86.519 (3.4055—3.4063)

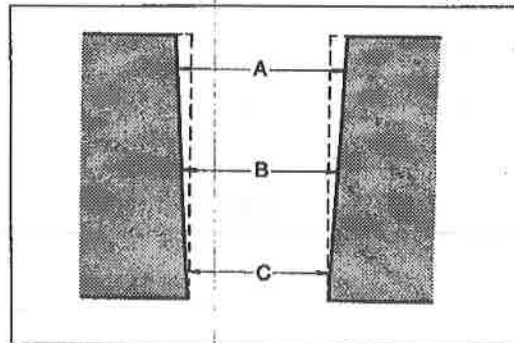

9MU0B2-259

- (1) If the cylinder bore exceeds the maximum, rebore the cylinder to oversize.
 (2) If the difference between the measurements A and C exceeds the maximum taper, rebore the cylinder to oversize.

Taper: 0.019mm (0.0004 in) max.

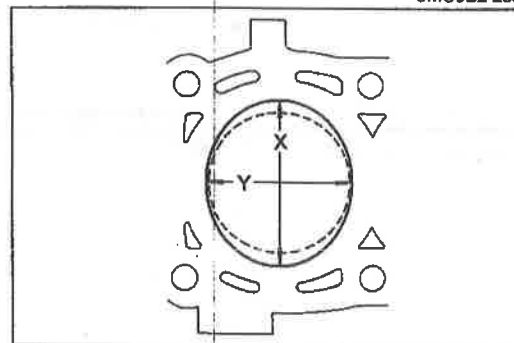

2BU0B1-018

- (3) If the difference between the measurements X and Y exceeds the maximum out-of-round, rebore the cylinder to oversize.

Out-of-round: 0.010mm (0.0004 in) max.

Caution

The boring size should be based on the size of an oversize piston and be the same for all cylinders.

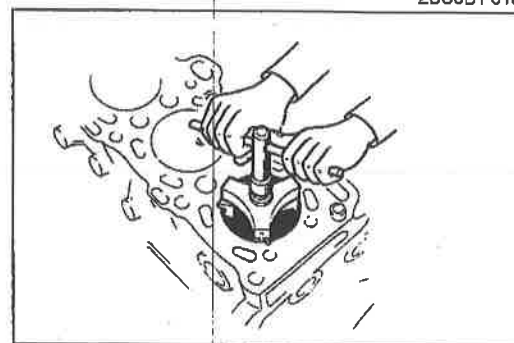

86U01X-102

5. If the upper part of the cylinder wall shows uneven wear, remove the ridge with a ridge reamer.

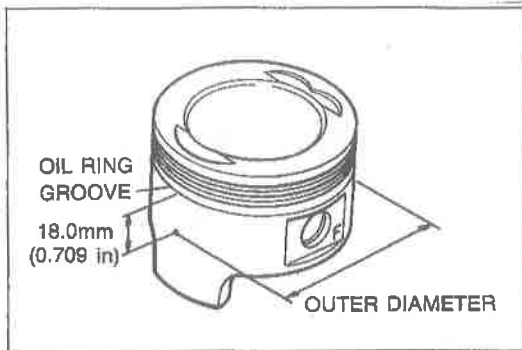

9BU0B1-058

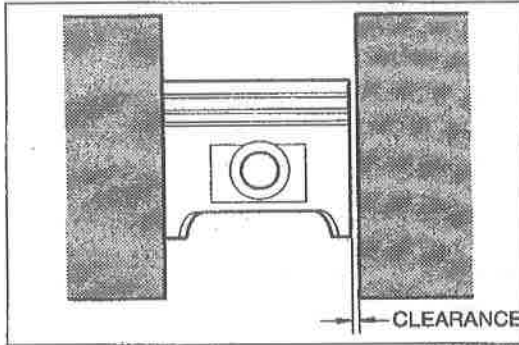

2BU0B1-019

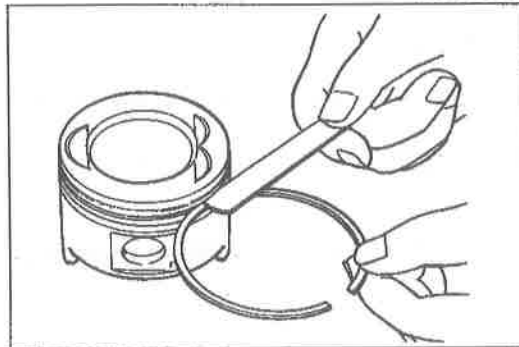

9MU0B2-262

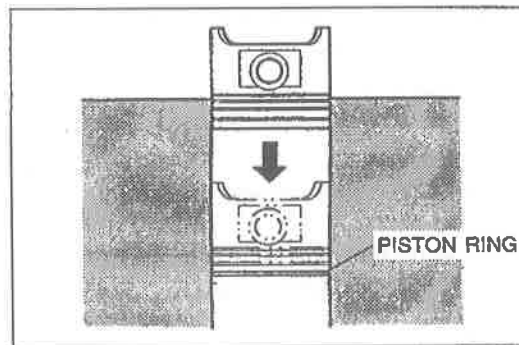

9MU0B2-263

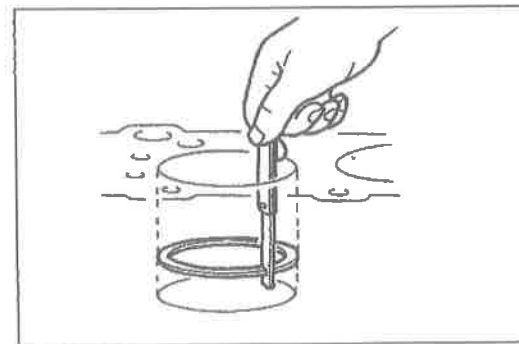

9BU0B1-060

Piston

1. Inspect the outer circumferences of all pistons for seizure or scoring. Replace if necessary.
2. Measure the outer diameter of each piston at a right angle (**90°**) to the piston pin, **18.0mm (0.709 in)** below the oil ring land lower edge.

Piston diameter

mm (in)

Size	Piston	Diameter
Standard		85.944—85.964 (3.3836—3.3844)
0.25 (0.010) oversize		86.194—86.214 (3.3935—3.3942)
0.50 (0.020) oversize		86.444—86.464 (3.4033—3.4041)

3. Check the piston-to-cylinder clearance.

Clearance: 0.043—0.062mm (0.0017—0.0024 in)
Maximum: 0.15mm (0.006 in)

4. If the clearance exceeds the maximum, replace the piston or rebores the cylinders to fit oversize pistons.

Note

If the piston is replaced, the piston rings must also be replaced.

Piston and Piston Rings

1. Measure the piston ring to ring land clearance around the entire circumference by using a new piston ring.

Clearance (Top and Second):
0.03—0.07mm (0.0012—0.0028 in)
Maximum: 0.15mm (0.006 in)

2. If the clearance exceeds the maximum, replace the piston.
3. Inspect the piston rings for damage, abnormal wear, or breakage. Replace if necessary.
4. Insert the piston ring into the cylinder by hand and use the piston to push it to the bottom of the ring travel.

5. Measure each piston ring end gap with a feeler gauge. Replace if necessary.

End gap

Top : 0.20—0.35mm (0.008—0.014 in)
Second: 0.15—0.30mm (0.006—0.012 in)
Oil rail : 0.20—0.70mm (0.008—0.028 in)
Maximum: 1.0mm (0.039 in)

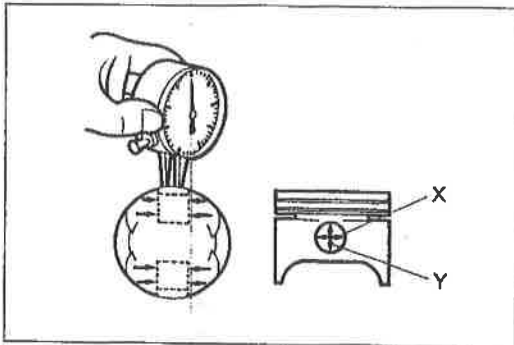

9BU0B1-061

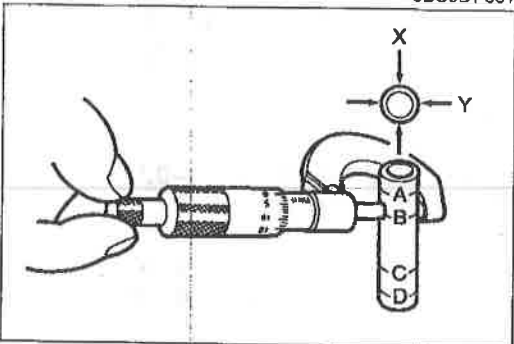

9BU0B1-062

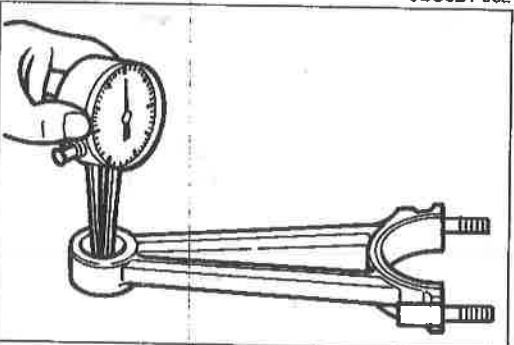

9BU0B1-063

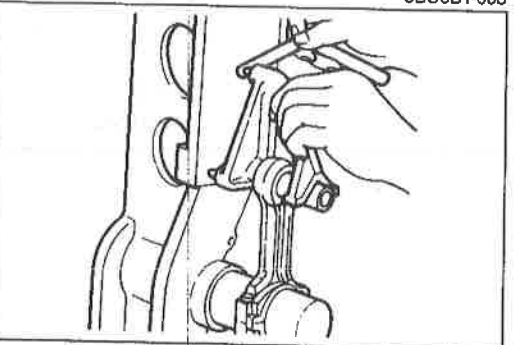

1BU0B1-012

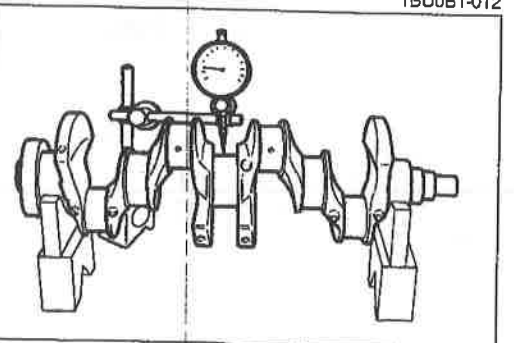

9MU0B2-131

Piston and Piston Pin

1. Measure the piston pin hole diameter in X and Y directions at four points.

Diameter: 21.988—21.998mm (0.8657—0.8661 in)

2. Measure the piston pin diameter in X and Y directions at four points.

Diameter: 21.974—21.980mm (0.8651—0.8654 in)

3. Check the piston pin-to-piston clearance.

Clearance: 0.008—0.024mm (0.0003—0.0009 in)

4. If the clearance exceeds the specification, replace the piston and/or piston pin.

Connecting Rod

1. Measure the connecting rod small end bore.

Diameter: 21.943—21.961mm (0.8640—0.8646 in)

2. Check the interference between the small end bore and piston pin.

Interference: 0.013—0.037mm (0.0005—0.0015 in)

3. Check each connecting rod for bend. Repair or replace if necessary.

Bend: 0.24mm (0.0094 in) max.

Length (Center to Center):

158.45—158.55mm (6.2382—6.2421 in)

If the connecting rod is replaced, the connecting rod cap and bolts must also be replaced because they are a matched set.

Crankshaft

1. Check the journals and pins for damage, scoring, or oil hole clogging.
2. Set the crankshaft on V-blocks.
3. Check the crankshaft runout at the center journal. Replace if necessary.

Runout: 0.03mm (0.0012 in) max.

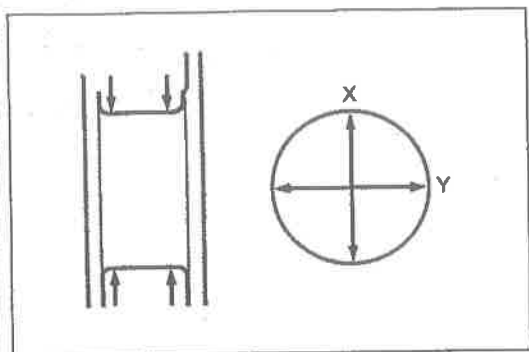

9BU0B1-097

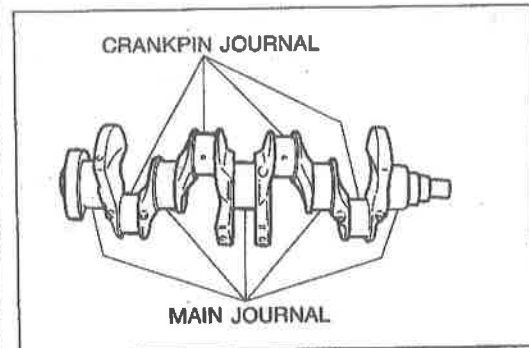

9BU0B1-064

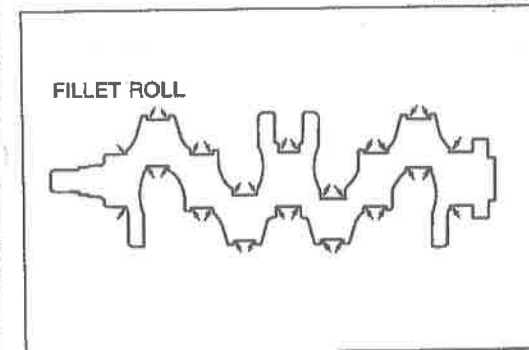

9BU0B1-065

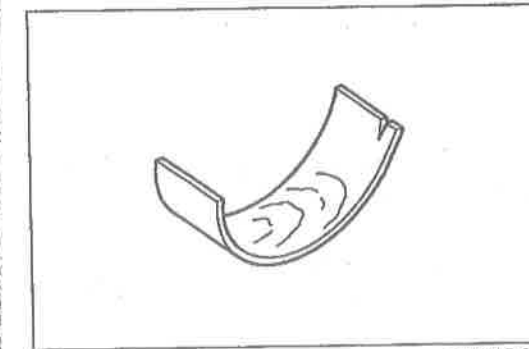

79G01C-077

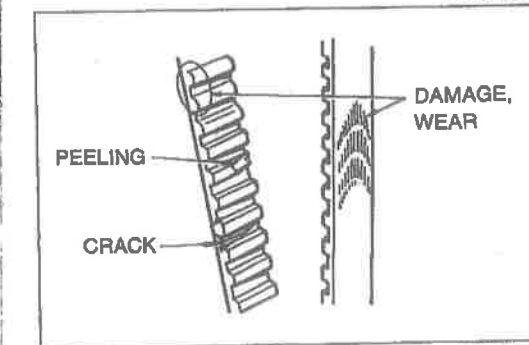

88U01X-113

4. Measure each journal diameter in X and Y directions at two places.

Main journal

Diameter: 59.937—59.955mm (2.3597—2.3604 in)

Out-of-round: 0.05mm (0.0020 in) max.

Crankpin Journal

Diameter: 50.940—50.955mm (2.0055—2.0061 in)

Out-of-round: 0.05mm (0.0020 in) max.

5. If the diameter is below the minimum, grind the journals to match an undersize bearing.

Undersize bearing: 0.25mm (0.010 in),

0.50 mm (0.020 in), 0.75mm (0.030 in)

Main journal diameter undersize

mm (in)

Bearing size		Journal diameter
0.25 (0.010) undersize	No.1,2,4,5	59.693—59.711 (2.3501—2.3508)
	No.3	59.687—59.705 (2.3499—2.3506)
0.50 (0.020) undersize	No.1,2,4,5	59.443—59.461 (2.3403—2.3410)
	No.3	59.437—59.455 (2.3400—2.3407)
0.75 (0.030) undersize	No.1,2,4,5	59.193—59.211 (2.3304—2.3311)
	No.3	59.187—59.205 (2.3302—2.3309)

Crankpin journal diameter undersize

mm (in)

Bearing size	Journal diameter
0.25 (0.010) undersize	50.690—50.705 (1.9957—1.9963)
0.50 (0.020) undersize	50.440—50.455 (1.9858—1.9864)
0.75 (0.030) undersize	50.190—50.205 (1.9760—1.9766)

Caution

Do not grind the fillet roll.

Main Bearing and Connecting Rod Bearing

Check the main bearings and the connecting rod bearings for peeling, scoring, or other damage.

Timing Belt

1. Replace the timing belt if there is any oil or grease on it.
2. Check the timing belt for damage, wear, peeling, cracks, or hardening. Replace if necessary.

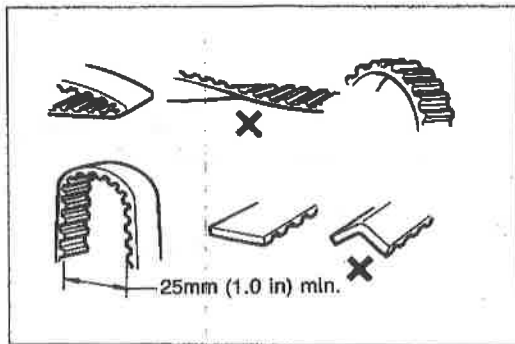

86U01X-114

Caution

- a) Never forcefully twist turn inside out, or bend the timing belt.
- b) Be careful not to allow oil or grease on the belt.

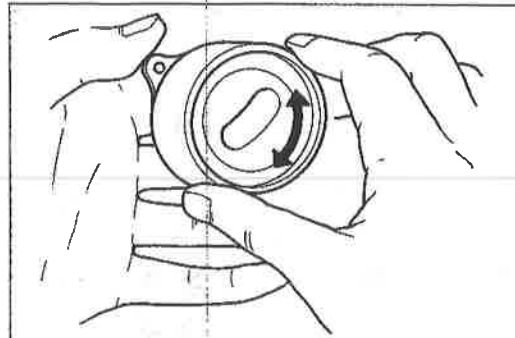

86U01X-115

Timing Belt Tensioner and Idler Pulley

Check the timing belt tensioner and idler pulley for smooth rotation and abnormal noise. Replace if necessary.

Caution

Do not clean the tensioner with cleaning fluids. If necessary, use a soft rag to wipe it clean, and avoid scratching it.

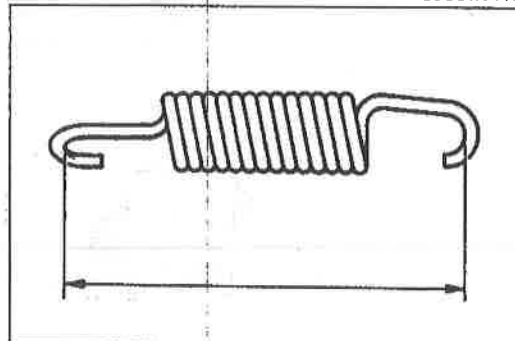

96U01X-045

Timing Belt Tensioner Spring

Check the free length of the tensioner spring. Replace if necessary.

Free length: 63.0mm (2.480 in)

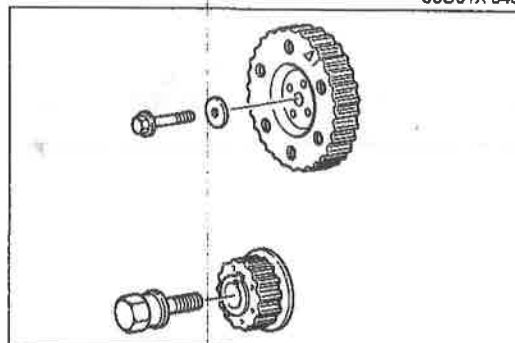

86U01X-117

Timing Belt Pulley and Camshaft Pulley

Inspect the pulley teeth for wear, deformation, or other damage. Replace if necessary.

Caution











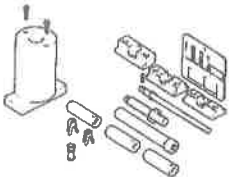

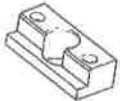



Do not clean the pulley with cleaning fluids. If necessary, use a rag to wipe it clean.

Timing Belt Cover (lower and upper)

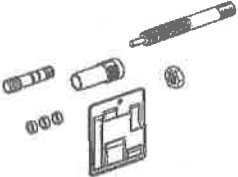
Inspect the timing belt covers for damage or cracks. Replace if necessary.

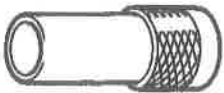
ASSEMBLY

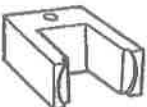
REPARATION ST

<p>49 L011 0A0</p> <p>Piston pin setting tool set</p> 	<p>49 L011 001</p> <p>Support block body (Part of 49 L011 0A0)</p> 	<p>49 L011 003</p> <p>Support block head (Part of 49 L011 0A0)</p> 
<p>49 L011 004</p> <p>Screw (Part of 49 L011 0A0)</p> 	<p>49 L011 005</p> <p>Stopper bolt (Part of 49 L011 0A0)</p> 	<p>49 L011 006</p> <p>Puller & installer (Part of 49 L011 0A0)</p> 
<p>49 L011 008</p> <p>Guide (Part of 49 L011 0A0)</p> 	<p>49 L011 010</p> <p>Centering tool (Part of 49 L011 0A0)</p> 	<p>49 L011 011</p> <p>Holder (Part of 49 L011 0A0)</p> 
<p>49 E011 1A0</p> <p>Ring gear brake set</p> 	<p>49 L012 0A0</p> <p>Installer set, valve seal & valve guide</p> 	<p>49 L012 001</p> <p>Installer (Part of 49 L012 0A0)</p> 
<p>49 L012 002</p> <p>Body (Part of 49 L012 0A0)</p> 	<p>49 L012 005</p> <p>Spacer (Part of 49 L012 0A0)</p> 	<p>49 0636 100A</p> <p>Arm, valve spring lifter</p> 
<p>49 G030 222</p> <p>Pivot, valve spring lifter</p> 	<p>49 SE01 310</p> <p>Centering tool, clutch disc</p> 	<p style="text-align: right;">2BU0B1-016</p>

1. Clean all parts before reinstallation.
2. Apply new engine oil to all sliding and rotating parts.
3. Replace plain bearings if they are peeling, burned, or otherwise damaged.
4. Tighten all bolts and nuts to the specified torques.

Caution

Do not reuse gaskets or oil seals.

9MU0B2-141

ASSEMBLY (CYLINDER BLOCK)

CYLINDER BLOCK I Torque Specifications

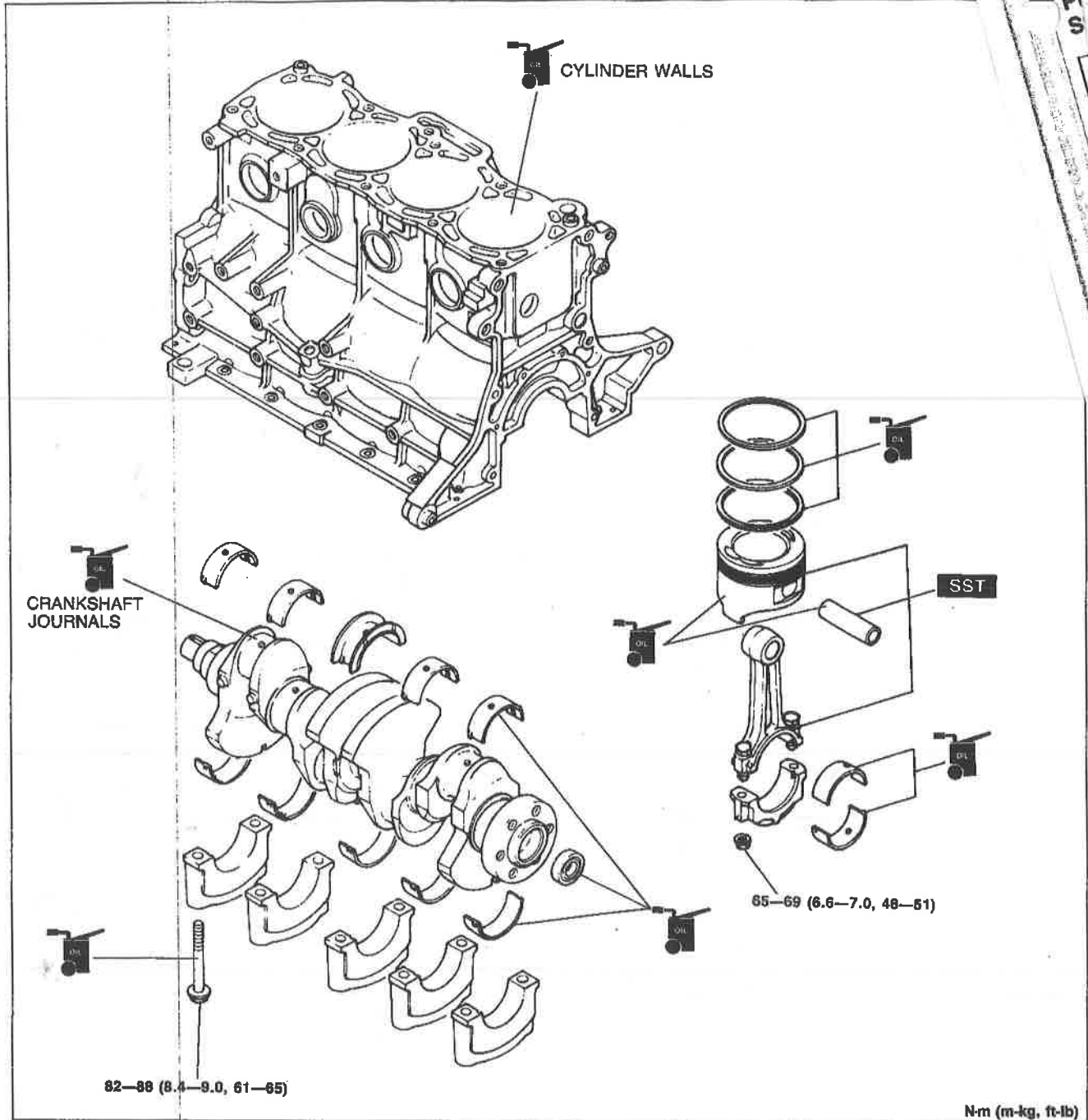

N-m (m-kg, ft-lb)
9BU0B1-114

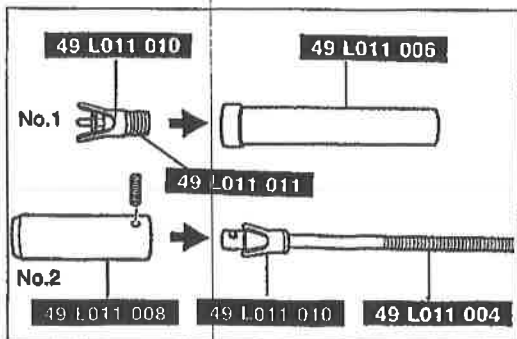

Connecting Rod
1. Assemble the **SST** as shown.

9MU0B2-143

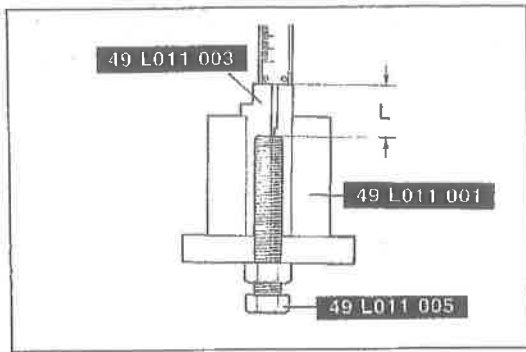

9MU0B2-144

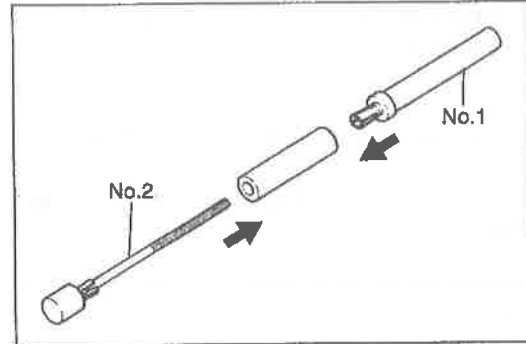

9MU0B2-145

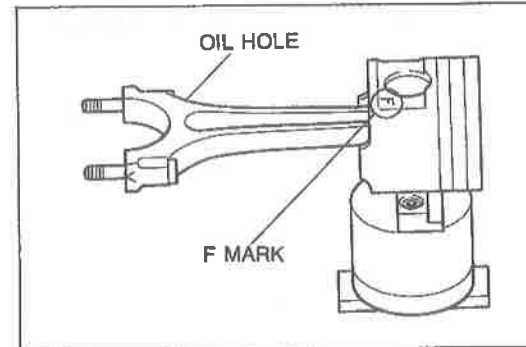

9BU0B1-066

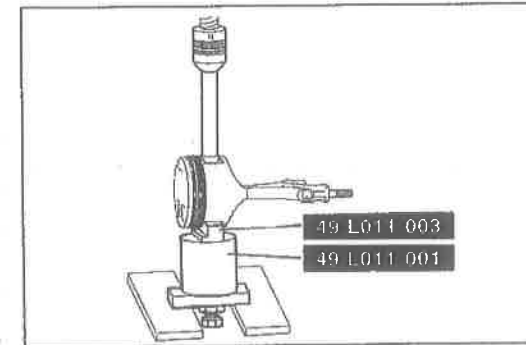

9BU0B1-067

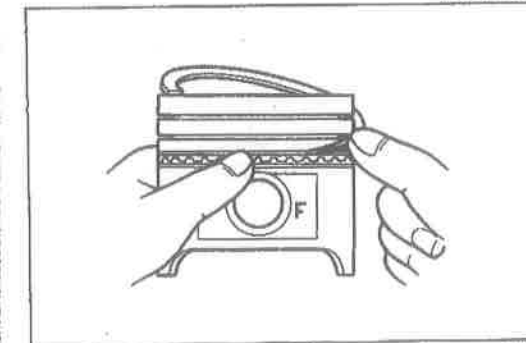

69G01A-144

2. Set the **stopper bolt** (49 L011 005) so that the depth **L** is as specified.

Depth L: 59.5—59.7mm (2.342—2.450 in)

3. Tighten the locknut.

4. Insert the **SST No.2** into the piston pin as shown and fully screw in the **SST No.1**.

5. Apply engine oil to the piston pin.

6. Set the piston on the **SST** with the **F** mark facing upward.
7. Align the oil hole of the large end of connecting rod and **F** mark on the piston as shown in the figure.

8. Press the piston pin into the piston and connecting rod until the **SST** contacts the stopper bolt.

9. While inserting the piston pin, check the pressure force. If it is less than specified, replace the piston pin or the connecting rod.

Pressure force:

4,905—14,715 N (500—1,500 kg, 1,100—3,300 lb)

10. Check the oscillation torque of the connecting rod.
(Refer to page B1-32.)

Piston Ring

1. Install the three-piece oil rings on the pistons.
 - (1) Apply engine oil to the oil ring spacer and rails.
 - (2) Install the oil ring spacer so that the opening faces upward.
 - (3) Install the upper rail and lower rail.

Note

- a) The upper rail and lower rail are the same.
- b) Each rail can be installed with either face upward.

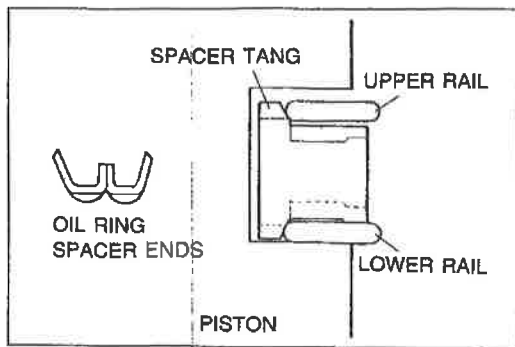

69G01A-145

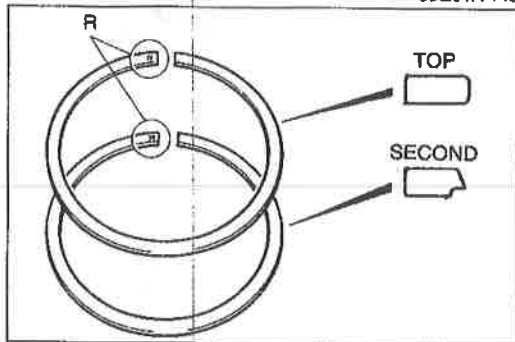

9MU0B2-148

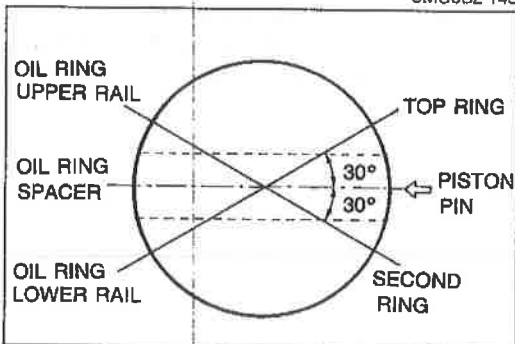

69G01A-147

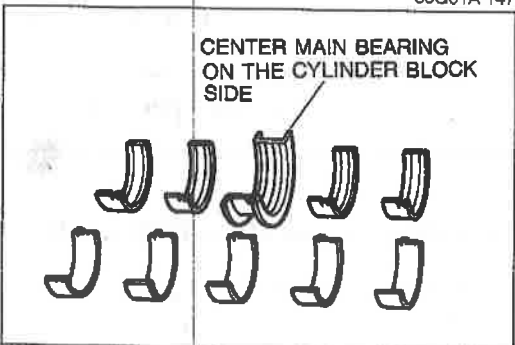

9BU0B1-068

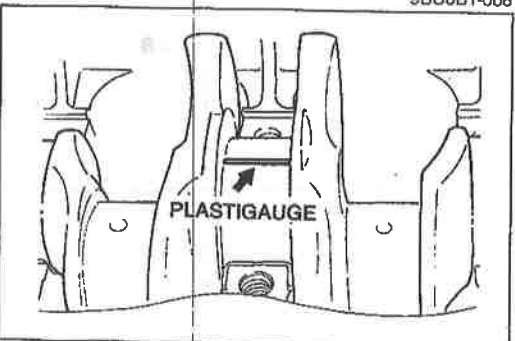

9MU0B2-266

2. Check that both rails are expanded by the spacer tangs as shown in the figure by checking that both rails turn smoothly in both directions.

3. Install the second ring to the piston first; then install the top ring. Use a piston ring expander.

Caution

a) The ring must be installed so that the "R" marks face upward.

b) The second ring must be installed with the scraper face downward.

4. Apply a liberal amount of clean engine oil to the second and top piston rings.

5. Position the opening of each ring as shown in the figure.

Crankshaft

1. Before installing the crankshaft, inspect the main bearing oil clearances as described.

Note

The center main bearing on the cylinder block side has thrust shoulders.

Oil clearance inspection

- (1) Remove any foreign material and oil from the journals and bearings.
- (2) Install the upper main bearings in the cylinder block.
- (3) Set the crankshaft in the cylinder block.
- (4) Position the Plastigauge on top of the journals in the axial direction.

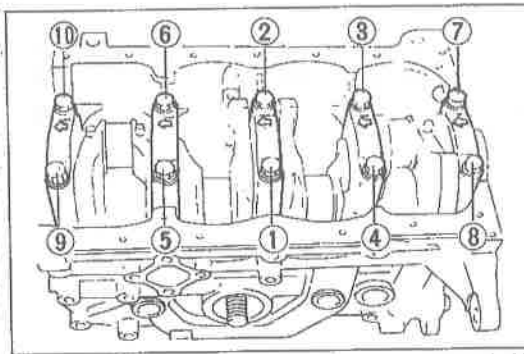

86U01X-123

- (5) Install the main bearing caps along with the lower main bearings according to the cap number and ← mark.
- (6) Tighten the caps in two or three steps in the order in the figure.

Tightening torque:
82—88 N·m (8.4—9.0 m·kg, 61—65 ft·lb)

Caution
Do not rotate the crankshaft when measuring the oil clearances.

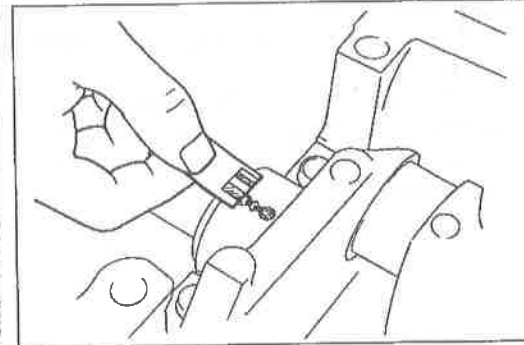

9BU0B1-069

- (7) Remove the main bearing caps, and measure the Plastigauge at each journal at the widest point for the smallest clearance, and at the narrowest point for the largest clearance.
 If the oil clearance exceeds specification, grind the crankshaft and use undersize main bearings.
 (Refer to page B1-44.)

Oil clearance
No. 1, 2, 4, 5: 0.025—0.043mm (0.0010—0.0017 in)
No. 3: 0.031—0.049mm (0.0012—0.0019 in)
Maximum: 0.08mm (0.0031 in)

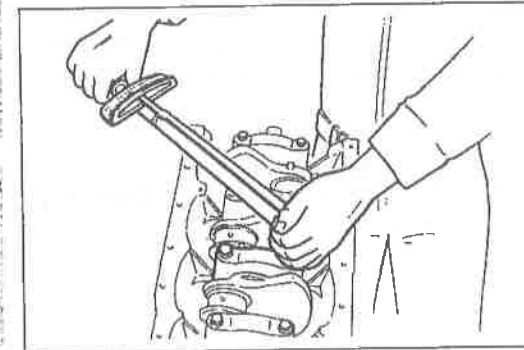

9MU0B2-274

2. Apply a liberal amount of engine oil to the main bearings and main journals.
3. Install the crankshaft and the main bearing caps according to the cap number and ← mark.
4. Verify that the crankshaft rotates smoothly by hand.

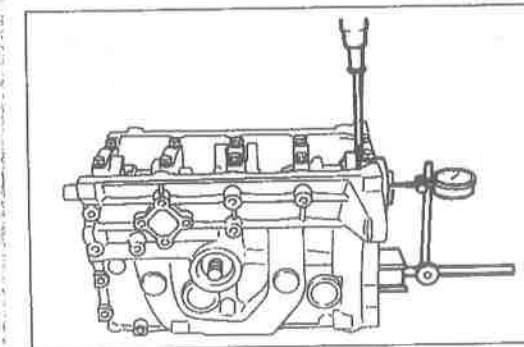

9MU0B2-267

5. Inspect the crankshaft end play.

End play: 0.08—0.18mm (0.0031—0.0071 in)
Maximum: 0.30mm (0.0118 in)

6. If the end play exceeds specification, grind the crankshaft and use an undersize center main bearing.

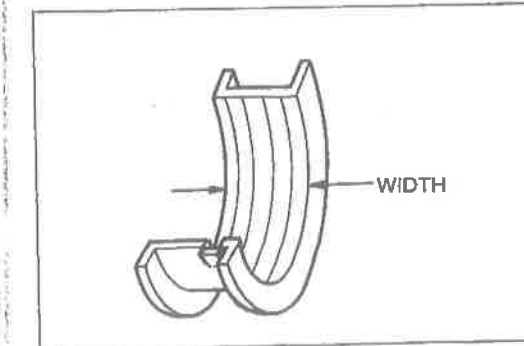

86U01X-216

Center main bearing width
Standard: 27.94—27.99mm (1.1000—1.1020 in)
0.25mm (0.010 in) undersize:
28.04—28.09mm (1.1040—1.1059 in)
0.50mm (0.020 in) undersize:
28.12—28.17mm (1.1071—1.1091 in)
0.75mm (0.030 in) undersize:
28.20—28.25mm (1.1102—1.1122 in)

Note
Wider thrust width is available only in undersize center main bearing

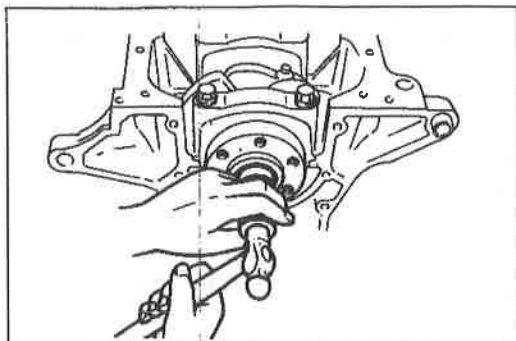

76G01B-075

Pilot Bearing

1. Apply engine oil to the outer circumference of the bearing.
2. Set a piece of pipe (outer diameter 30—34mm, 1.18—1.34 in) against the outer race of the bearing; then tap it evenly into the crankshaft.
3. Lubricate the bearing with grease.

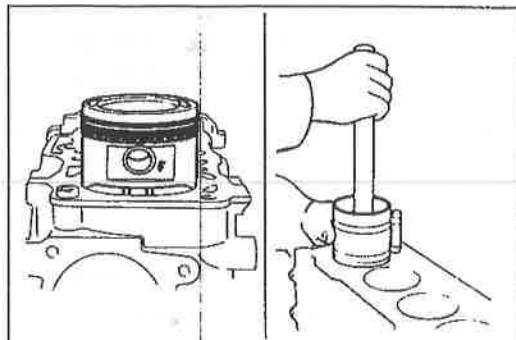

9MU0B2-269

Piston and Connecting Rod Assembly

1. Apply a liberal amount of clean engine oil to the cylinder walls, pistons, and rings.
2. Check the piston rings for the end gap alignment.
3. Insert each piston assembly into the cylinder block with the **F** mark facing the front of the engine. Use a piston installer tool (commercially available).

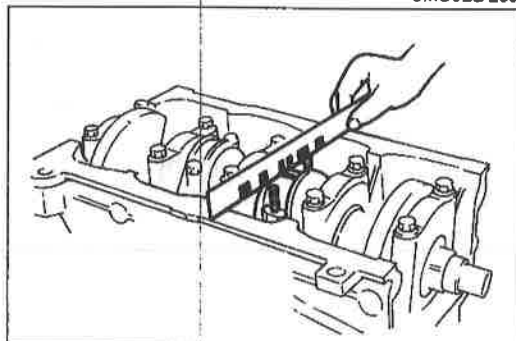

9MU0B2-152

Connecting Rod Cap

1. Check the connecting rod bearing clearances using the same procedure as used for the main bearing oil clearance.

Connecting rod cap tightening torque:

65—69 N·m (6.6—7.0 m·kg, 48—51 ft·lb)

Oil clearance: 0.027—0.067mm (0.0011—0.0026 in)

Maximum: 0.10mm (0.004 in)

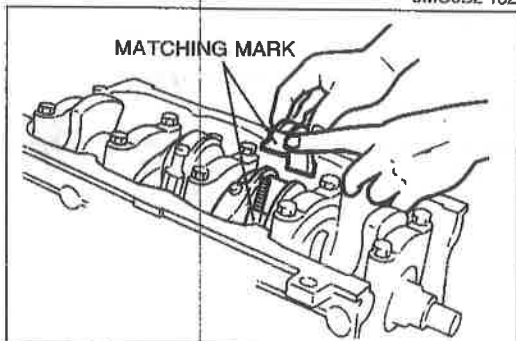

9BU0B1-070

Caution

Align the matching marks on the cap and on the connecting rod when installing the connecting rod cap.

2. If the oil clearance exceeds specification, grind the crankshaft and use undersize bearings. (Refer to page B1-44.)

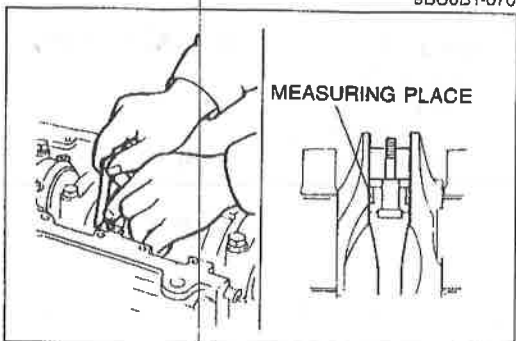

9MU0B2-270

3. Check the side clearance of each connecting rod without the cap installed.

Side clearance: 0.110—0.262mm (0.0043—0.0103 in)
Maximum: 0.30mm (0.012 in)

If the clearance exceeds the maximum, replace the connecting rod.

B1

ASSEMBLY (CYLINDER BLOCK)

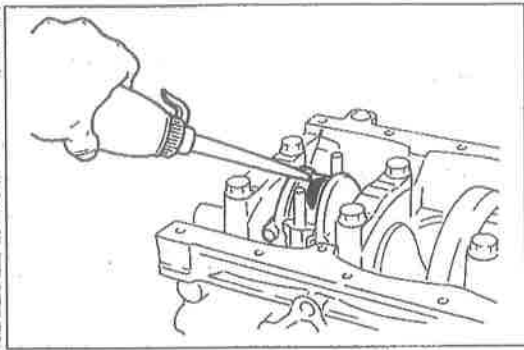

9MU0B2-154

4. Apply a liberal amount of engine oil to the crankpin journal and connecting rod bearing.
5. Install the connecting rod cap with the alignment marks aligned.

Tightening torque:
65–69 N·m (6.6–7.0 m·kg, 48–51 ft·lb)

6. Verify that the crankshaft rotates smoothly by hand.

CYLINDER BLOCK II Torque Specifications

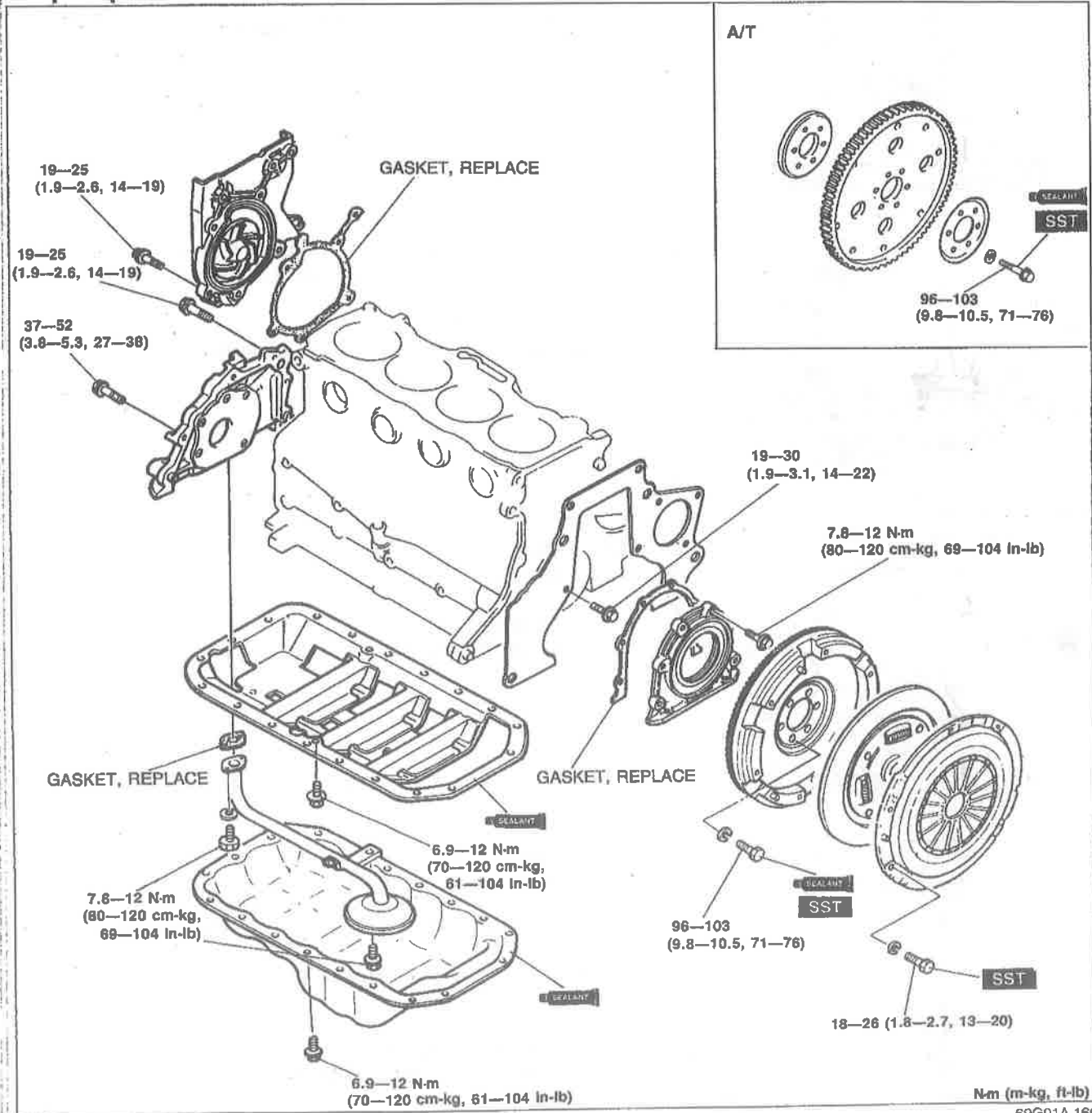

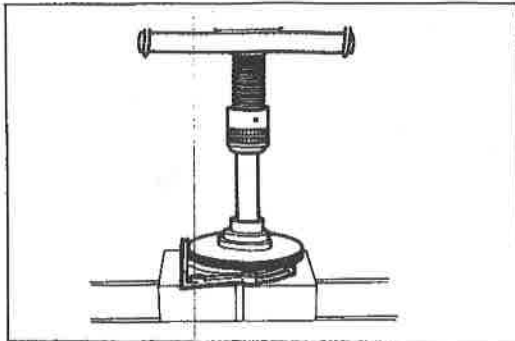

9BU0B1-099

Rear Cover

1. Apply engine oil to the rear cover and new oil seal lip.
2. Fit the oil seal onto the rear cover.
3. Press the oil seal in evenly using a suitable pipe.

Oil seal outer diameter: 110mm (4.33 in)

Caution

The oil seal must be pressed in until it is flush with the edge of the rear cover.

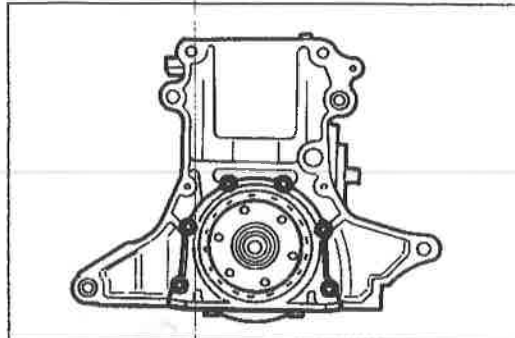

9BU0B1-100

4. Install the rear cover and a new gasket.

Tightening torque:

7.8—12 N·m (80—120 cm·kg, 69—104 in·lb)

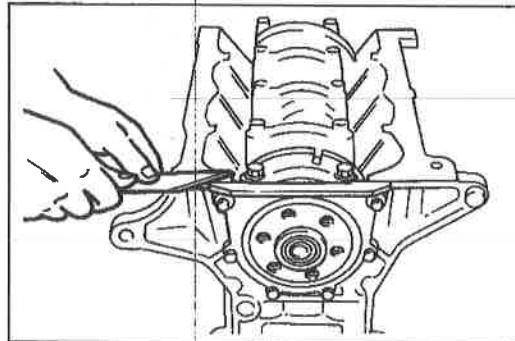

86U01X-132

5. Cut away the portion of the gasket that projects out from the rear cover assembly toward the oil pan side.

Caution

Do not scratch the rear cover assembly.

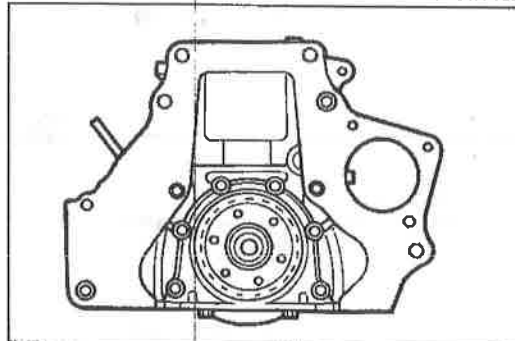

4BG01A-160

End Plate

Install the end plate.

Tightening torque:

19—30 N·m (1.9—3.1 m·kg, 14—22 ft·lb)

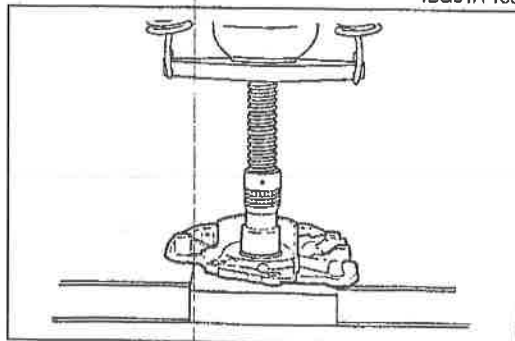

9BU0B1-101

Oil Pump

1. Apply engine oil to the oil pump body and new oil seal lip.
2. Fit the oil seal onto the oil pump body.
3. Press the oil seal in evenly using a suitable pipe.

Oil seal outer diameter: 48mm (1.89 in)

Caution

The oil seal must be pressed in until it is flush with the edge of the oil pump body.

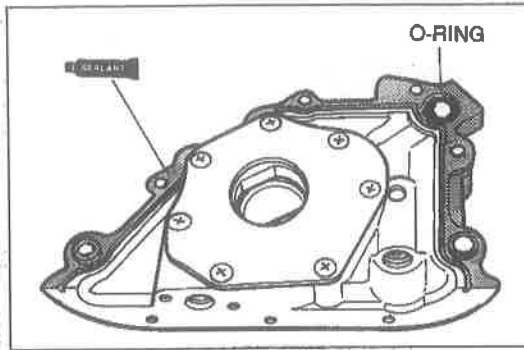

96U01X-072

4. Apply engine oil to the oil seal lip.
5. Remove any dirt or other material from the contact surfaces.
6. Apply a continuous bead of silicon sealant to the contact surface of the oil pump.
7. Install a new O-ring into the pump body.

Caution

Do not allow any sealant to get into the oil hole.

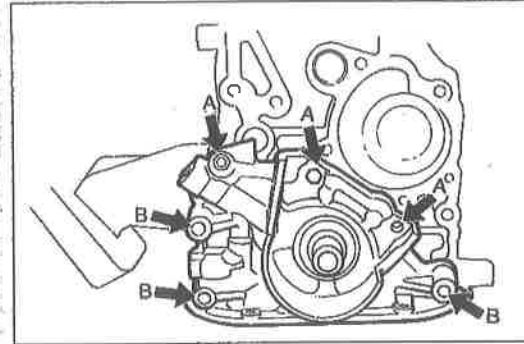

96U01X-073

8. Install the oil pump.

Tightening torque

- (A): 19—25 N·m (1.9—2.6 m·kg, 14—19 ft·lb)
- (B): 37—52 N·m (3.8—5.3 m·kg, 27—38 ft·lb)

9. Remove any sealant which has been squeezed out.

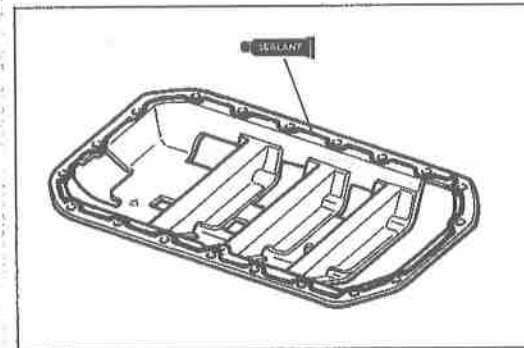

9BU0B1-102

Stiffener

1. Remove any dirt or other material from the contact surface.
2. Apply a continuous bead of silicone sealant to the stiffener along the inside of the bolt holes, and overlap the ends.
3. Install the stiffener.

Tightening torque:

6.9—12 N·m (70—120 cm·kg, 61—104 in·lb)

Caution

After the sealant is applied, the oil pan must be secured within 30 minutes.

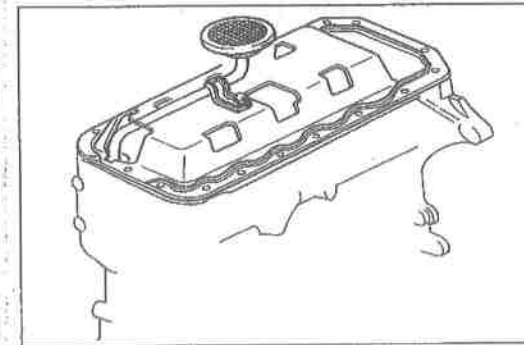

9BU0B1-103

Oil Strainer

Install the oil strainer and a new gasket.

Tightening torque:

7.8—12 N·m (80—120 cm·kg, 69—104 in·lb)

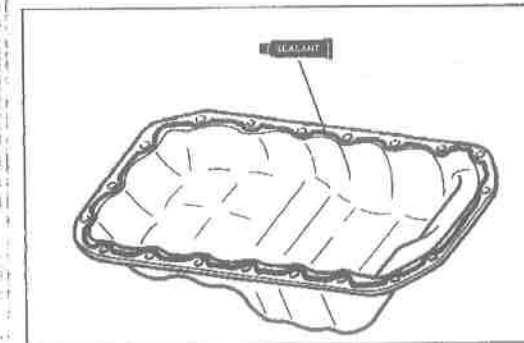

9BU0B1-104

Oil Pan

1. Apply a continuous bead of silicone sealant to the oil pan around the inside of the bolt holes and overlap the ends.
2. Install the oil pan.

Tightening torque:

6.9—12 N·m (70—120 cm·kg, 61—104 in·lb)

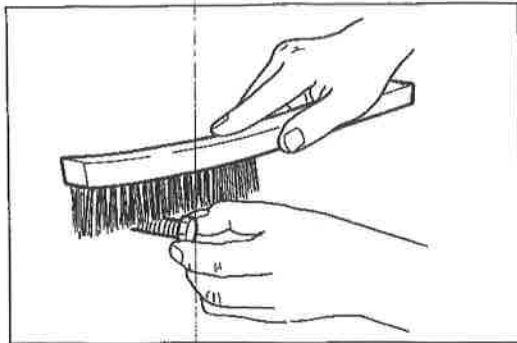

86U01X-138

Flywheel (M/T), Drive Plate (A/T)

1. Remove any old sealant from the bolts and bolt holes. If old sealant cannot be removed from the bolt, replace it.
2. Apply sealant to the bolt threads.

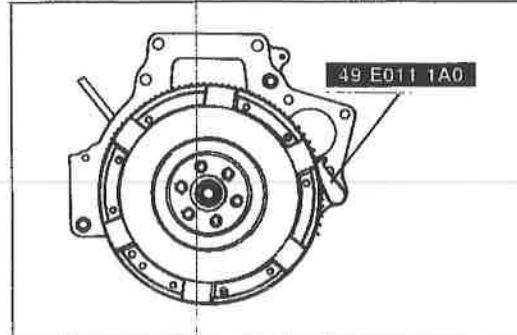

86U01X-139

(M/T)

3. Install, and tighten the flywheel with the **SST**.

Tightening torque:

96—103 N·m (9.8—10.5 m·kg, 71—76 ft·lb)

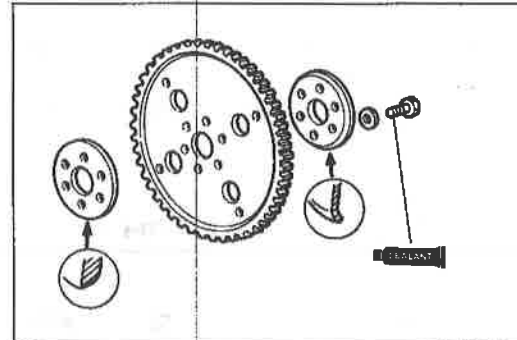

76F01C-049

(A/T)

4. Install, and tighten the drive plate adapter, drive plate, and backing plate with the **SST**.

Tightening torque:

96—103 N·m (9.8—10.5 m·kg, 71—76 ft·lb)

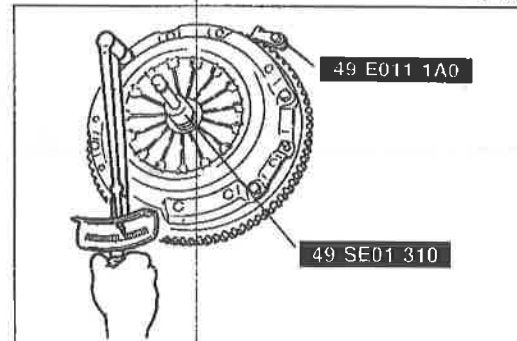

98U0B1-071

Clutch Disc and Clutch Cover (M/T)

Install the clutch disc and clutch cover using the **SST**. (Refer to Section H.)

Tightening torque:

18—26 N·m (1.8—2.7 m·kg, 13—20 ft·lb)

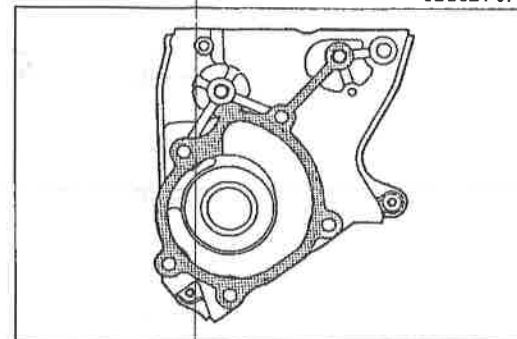

96U01X-053

Water Pump

1. Remove all dirt, grease, and other material from the water pump mounting surface.
2. Place a new gasket in position.

ASSEMBLY (CYLINDER HEAD)

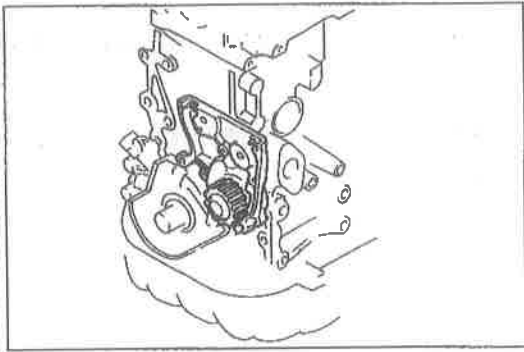

7BU01B-103

3. Install the water pump.

Tightening torque:
19—25 N·m (1.9—2.6 m·kg, 14—19 ft·lb)

CYLINDER HEAD Torque Specifications

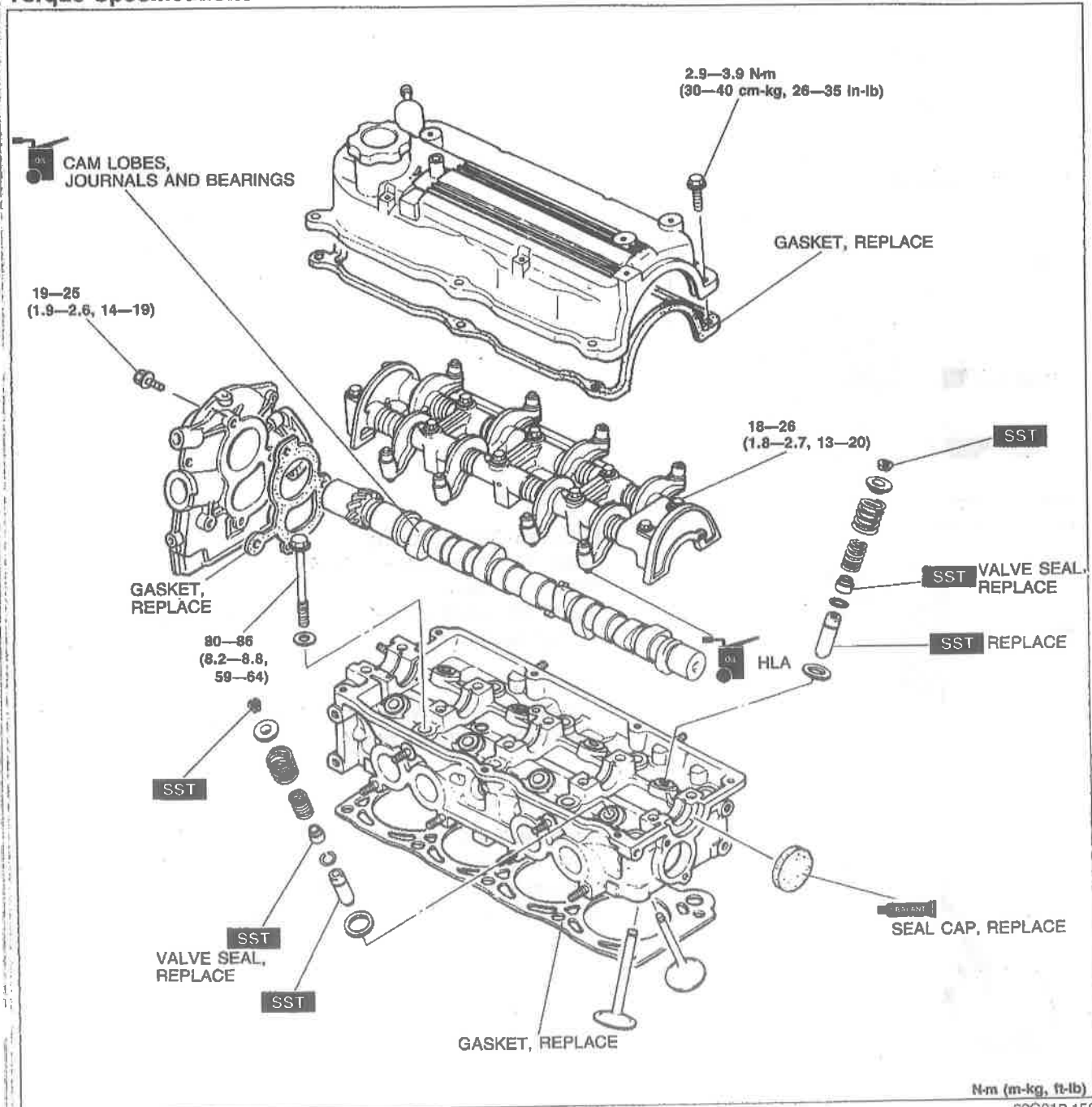

69G01B-152

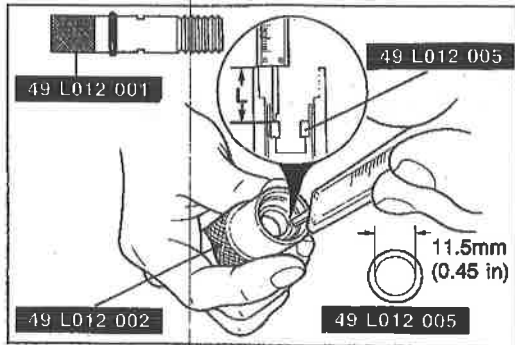

9BU0B1-072

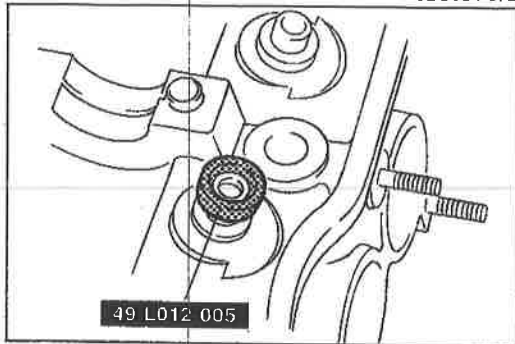

0BU0B1-022

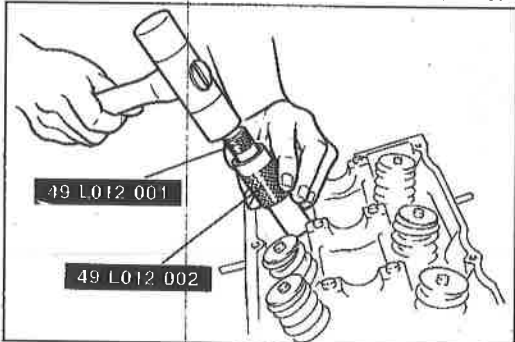

9MU0B2-190

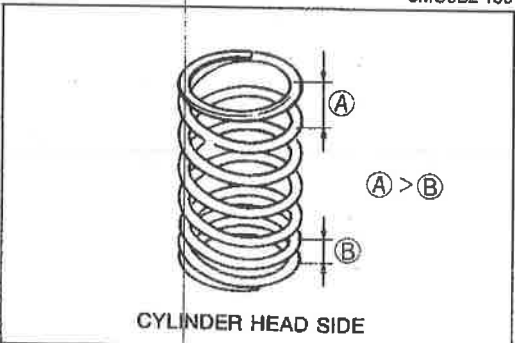

9BU0B1-073

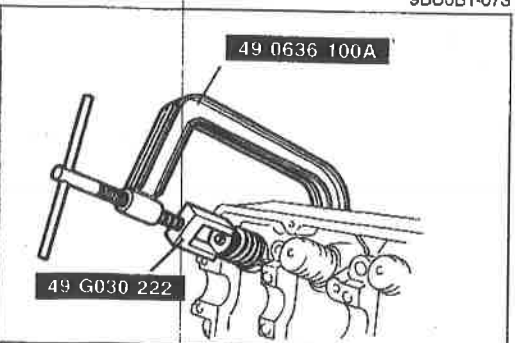

86U01X-145

Valve Seal

1. Assemble the **SST** as shown so that the depth **L** is as specified.

Depth L: 21.6—22.0mm (0.850—0.866 in)

2. Install a new valve seal onto the valve guide.
3. Install the **SST** onto the valve seal.

4. Tap the valve seal in until the **SST** contacts the cylinder head.

Valve and Valve Spring

1. Install the lower spring seat.
2. Install the valve.
3. Install the valve springs (outer and inner) and the upper spring seat.

Note

Install the outer valve spring with the closer pitch toward the cylinder head.

4. Compress the valve spring with the **SST**; then install the valve keepers.
5. Tap the end of the valve stem lightly two or three times with a plastic hammer to confirm that the keepers are all fully seated.

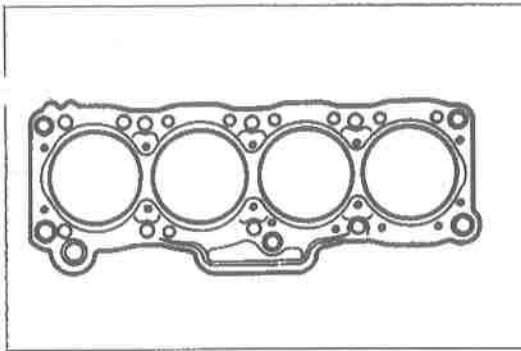

86U01X-146

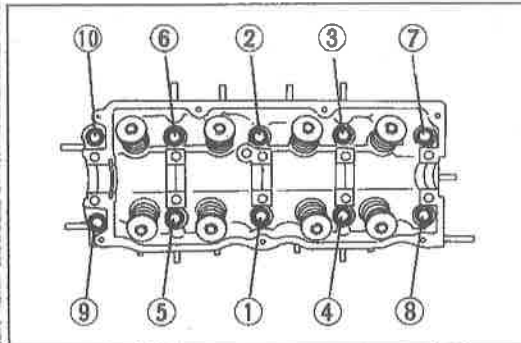

86U01X-147

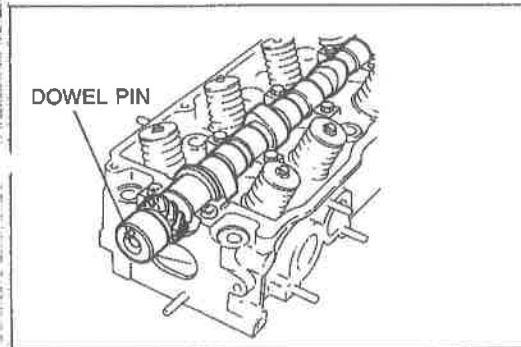

86U01X-148

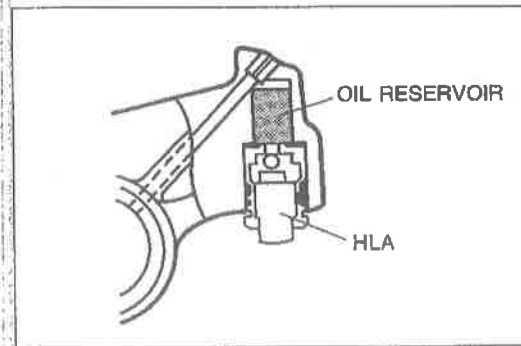

86U01X-149

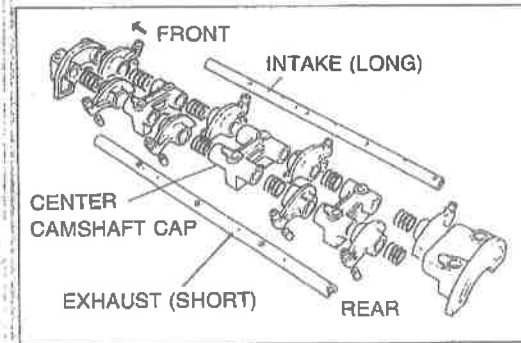

98U0B1-074

Cylinder Head

1. Thoroughly remove all dirt, oil, or other material from the top of the cylinder block.
2. Place the new cylinder head gasket in position.

3. Install the cylinder head.
4. Apply engine oil to the bolt threads and seat faces.
5. Tighten the cylinder head bolts in two or three steps in the order shown in the figure.

Tightening torque:

80—86 N·m (8.2—8.8 m·kg, 59—64 ft·lb)

Camshaft

1. Apply a liberal amount of engine oil to the journals and bearings.
2. Place the camshaft in position with the dowel pin facing straight up.

Hydraulic Lash Adjuster (HLA)

1. Pour engine oil into the oil reservoir in the rocker arm.
2. Apply engine oil to the new HLA.
3. Carefully install the HLA into the rocker arm.

Caution

Be careful not to damage the O-ring when installing the HLA.

Camshaft Cap, Rocker Arm and Shaft Assembly

1. Assemble the rocker arm and shaft assembly as shown in the figure.

Caution

Be sure that rocker arm shaft oil holes (in the center camshaft cap) face each other.

Note

Use the installation bolts for alignment.

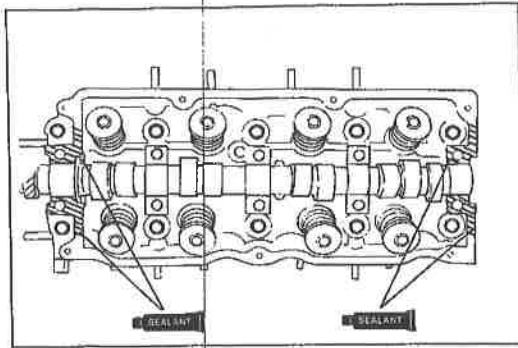

9BU0B1-075

2. Apply silicone sealant to the shaded areas shown in the figure.
3. Apply liberal amount of clean engine oil to the cam lobes and journals.

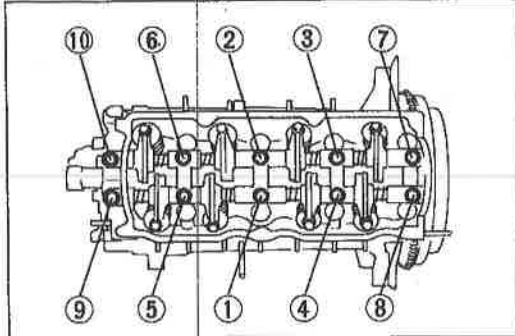

9BU0B1-076

4. Install the rocker arm and shaft assemblies. Tighten the bolts in two or three steps in the order shown in the figure.

Tightening torque:

18—26 N·m (1.8—2.7 m·kg, 13—20 ft·lb)

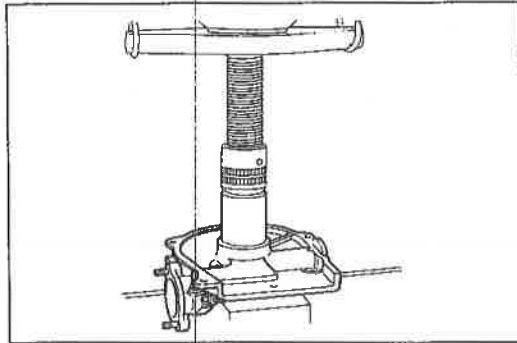

86U01X-155

Front Housing

1. Apply engine oil to the front housing and a new oil seal.
2. Press the oil seal into the front housing.

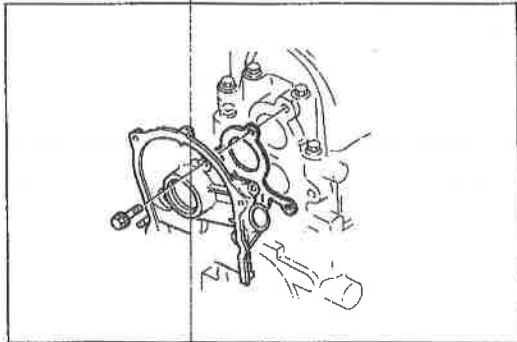

86U01X-156

3. Apply engine oil to the oil seal lip.
4. Install the front housing and a new gasket.

Tightening torque:

19—25 N·m (1.9—2.6 m·kg, 14—19 ft·lb)

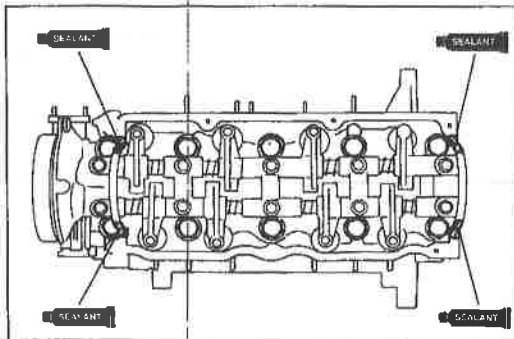

9BU0B1-105

Cylinder Head Cover

1. Apply silicon sealant to the shaded areas shown in the figure.
2. Install the cylinder head cover.

Tightening torque:

2.9—3.9 N·m (30—40 cm·kg, 26—35 in·lb)

B1

ASSEMBLY (TIMING BELT)

TIMING BELT Torque Specifications

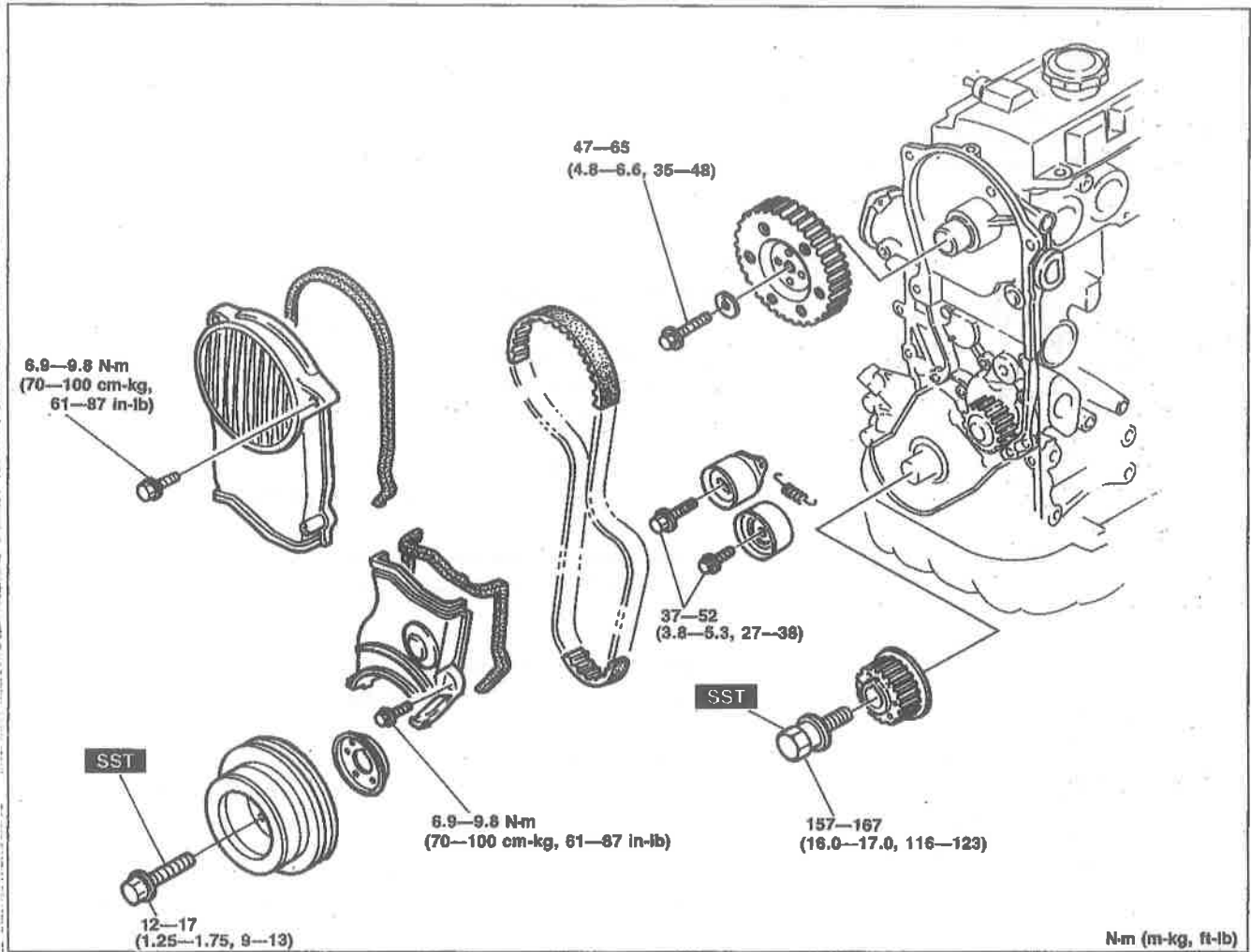

N-m (m-kg, ft-lb)

69G01B-160

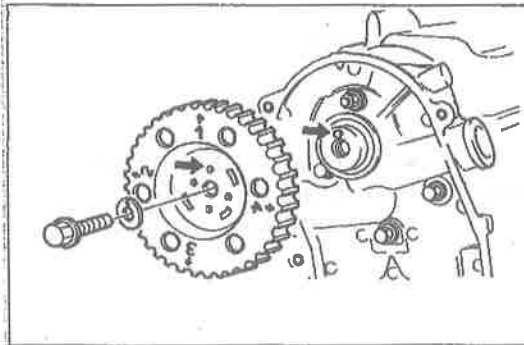

96U01X-056

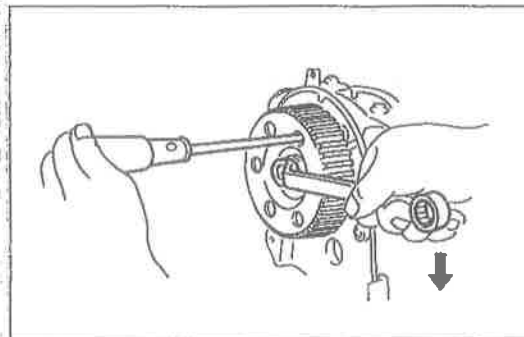

76G01A-141

Camshaft Pulley

1. Install the camshaft pulley on the camshaft with the dowel pin fit into the hole at the **↑1** mark.

2. Tighten the camshaft pulley lock bolt.

Tightening torque:

47-65 N-m (4.8-6.6 m-kg, 35-48 ft-lb)

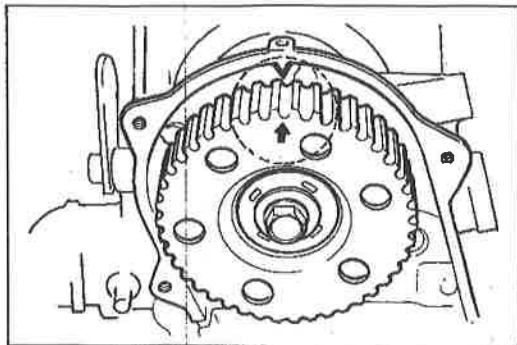

96U01X-057

3. Align the **↑1** mark on the pulley with the matching mark on the front housing.

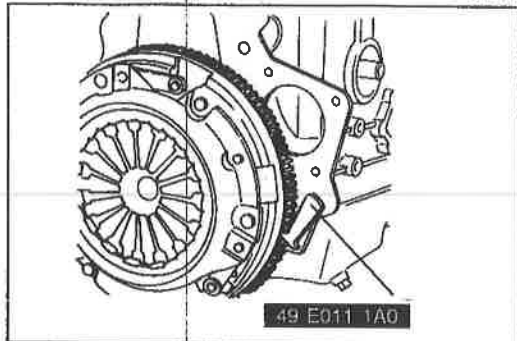

0BU0B1-015

Timing Belt Pulley

1. Reverse the direction of the **SST**.
(Refer to page B1-55.)
2. Install the crankshaft key.
3. Install the timing belt pulley on the crankshaft.

Tightening torque:

157—167 N·m (16.0—17.0 m·kg, 116—123 ft·lb)

4. Release the ring gear brake.
5. Align the timing belt pulley and the oil pump body matching marks.

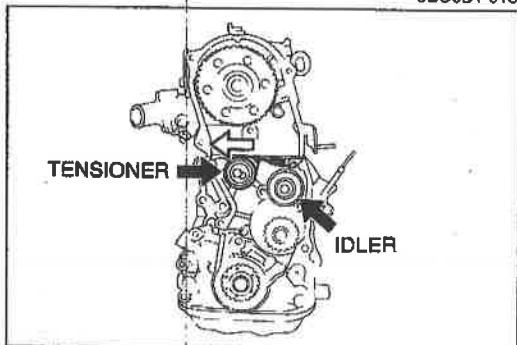

69G01B-165

Timing Belt Idler Pulley

Install the timing belt idler pulley.

Tightening torque:

37—52 N·m (3.8—5.3 m·kg, 27—38 ft·lb)

Timing Belt Tensioner

1. Install the timing belt tensioner and tensioner spring.
2. Tentatively secure the tensioner with the spring fully extended.

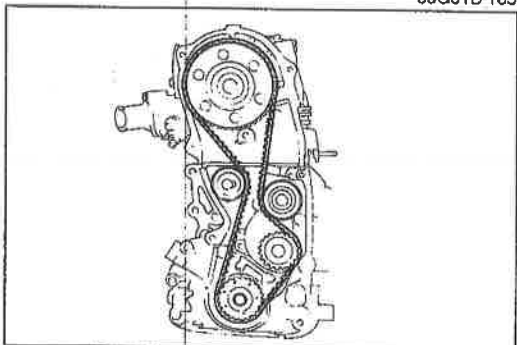

76G01A-085

Timing Belt

1. Install the timing belt. (keep the tension side of belt as tight as possible.)

Caution

- a) If the timing belt is being reused, it must be reinstalled to rotate in the original direction.
- b) Check that there is no oil, grease, or dirt on the timing belt.

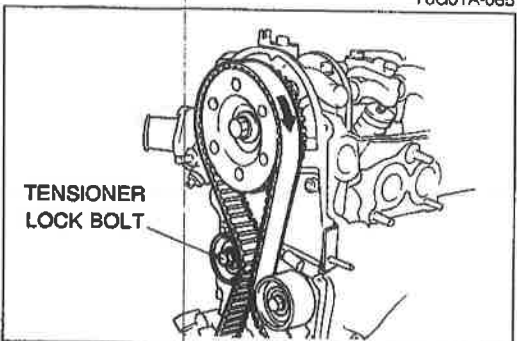

96U01X-059

2. Turn the crankshaft twice in the direction of rotation.
3. Check that the matching marks are correctly aligned. If not aligned, remove the timing belt and tensioner, and repeat the above-mentioned procedure.
4. Loosen the tensioner lock bolt and apply tension to the belt.

ASSEMBLY (TIMING BELT)

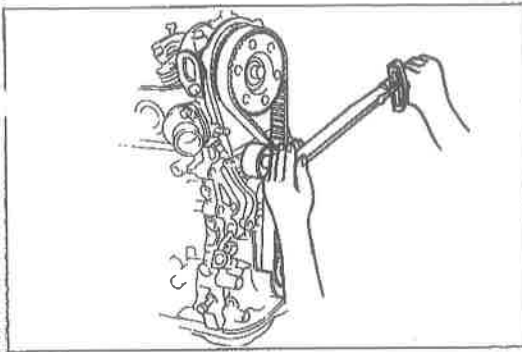

96U01X-060

5. Tighten the timing belt tensioner lock bolt.

Tightening torque:

37—52 N·m (3.8—5.3 m·kg, 27—38 ft·lb)

6. Turn the crankshaft twice in the direction of rotation and align the matching marks.

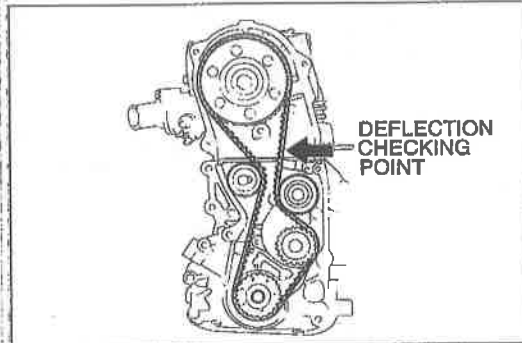

9BU0B1-077

7. Check the timing belt deflection.

If the deflection is not correct, loosen the tensioner lock bolt and repeat steps 3—5 above. Replace the tensioner spring if necessary.

Belt deflection/98 N (10 kg, 22 lb)

New : 8.0—9.0mm (0.31—0.35 in)

Used: 9.0—10.0mm (0.35—0.39 in)

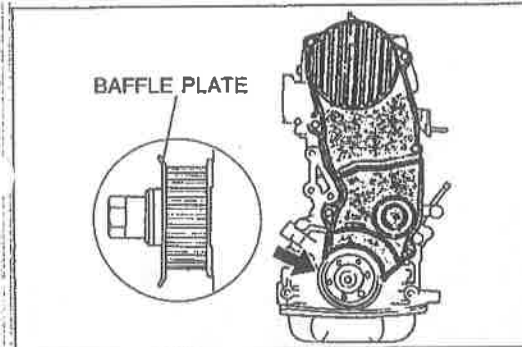

9BU0B1-107

Baffle Plate

Position the baffle plate on the timing belt pulley.

Timing Belt Cover

Install the lower timing belt cover, upper timing belt cover, and new gaskets.

Tightening torque:

6.9—9.8 N·m (70—100 cm·kg, 61—87 in·lb)

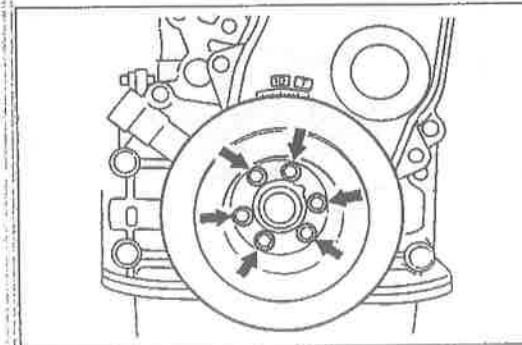

9BU0B1-108

Crankshaft Pulley

Install the crankshaft pulley.

Tightening torque:

12—17 N·m (1.25—1.75 m·kg, 9—13 ft·lb)

AUXILIARY PARTS Torque Specification

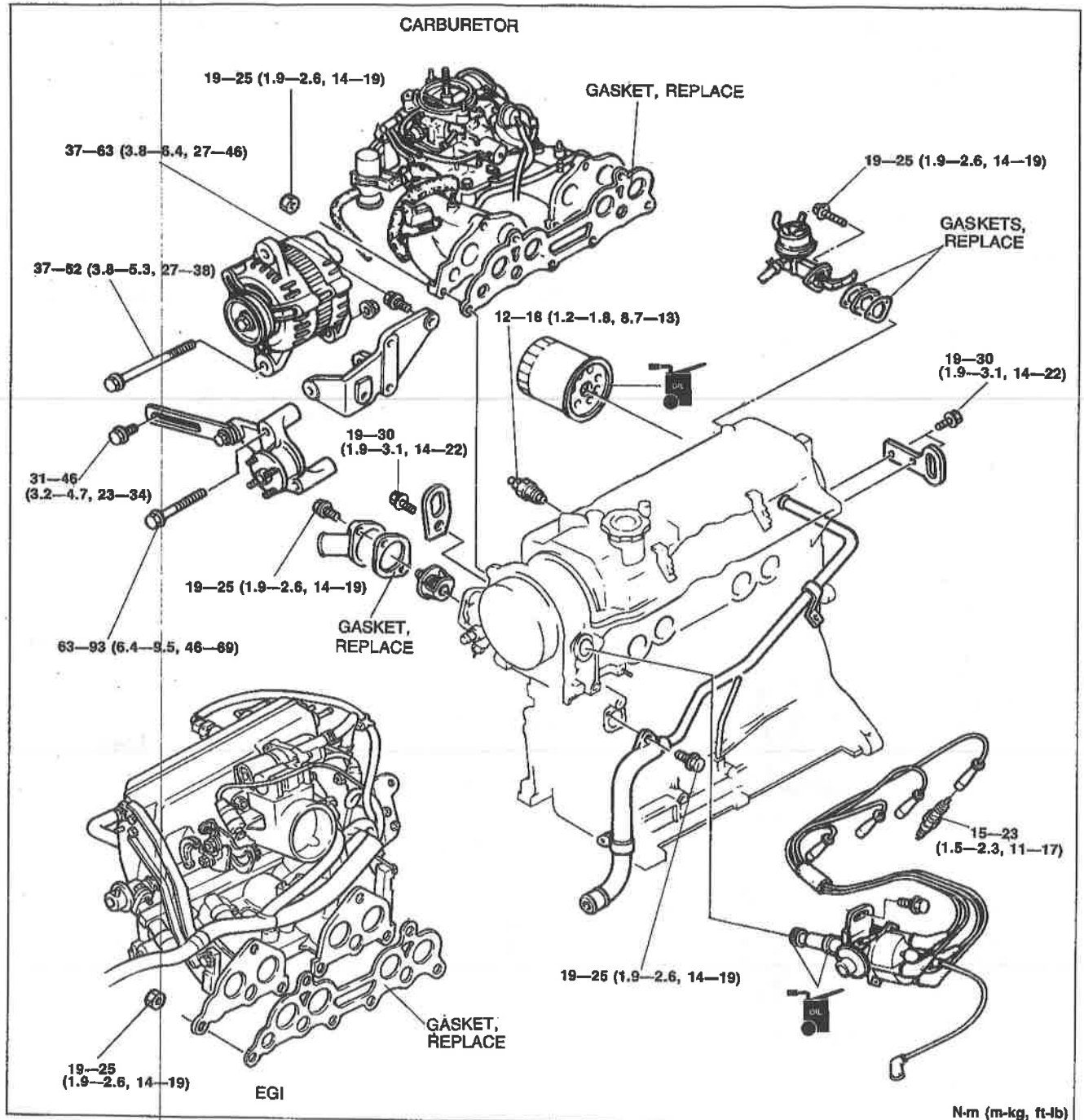

9MU0B2-201

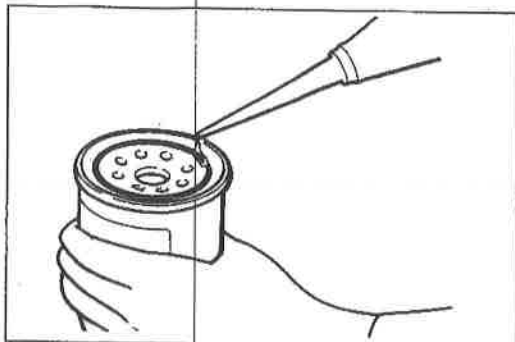

9BU0B1-078

Oil Pressure Switch
Install the oil pressure switch.

Tightening torque:
12-18 N-m (1.2-1.8 m-kg, 8.7-13 ft-lb)

Oil Filter

1. Apply a small amount of engine oil to the rubber seal of the new filter.
2. Install the oil filter and tighten it by hand until the rubber seal contacts the base.
3. Then tighten the filter 1-1/6 turn with a wrench.

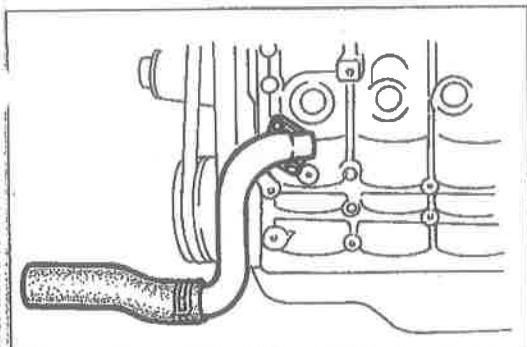

9MU0B2-214

Coolant Inlet Pipe and Bypass Pipe

1. Install the coolant inlet pipe with a new gasket.

Tightening torque:

19—25 N·m (1.9—2.6 m·kg, 14—19 ft·lb)

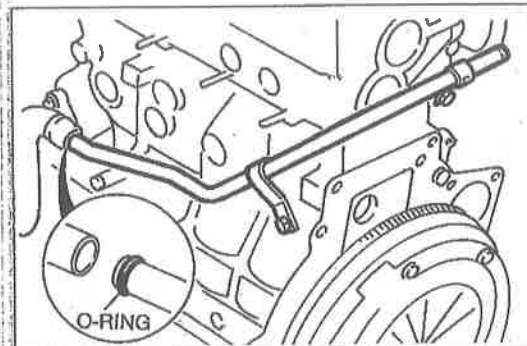

9BU0B1-109

2. Apply vegetable oil to the new O-ring.
3. Install the coolant bypass pipe.

Tightening torque:

19—25 N·m (1.9—2.6 m·kg, 14—19 ft·lb)

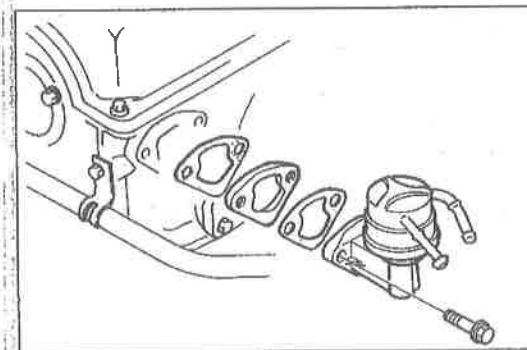

0BU0B1-010

Fuel Pump (Carburetor M/T)

1. Apply engine oil to the fuel cam contact surface.
2. Install the fuel pump with the insulator and new gaskets.

Tightening torque:

19—25 N·m (1.9—2.6 m·kg, 14—19 ft·lb)

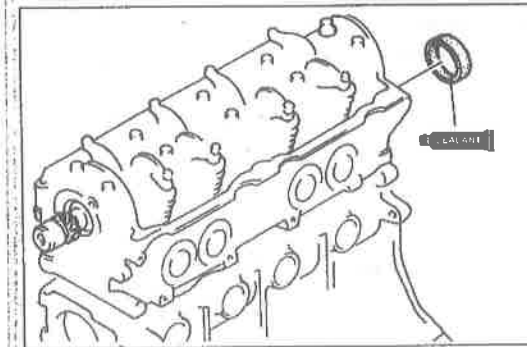

9BU0B1-080

Seal Cap

1. Apply silicone sealant to the new seal cap.
2. Install the seal cap into the cylinder head.

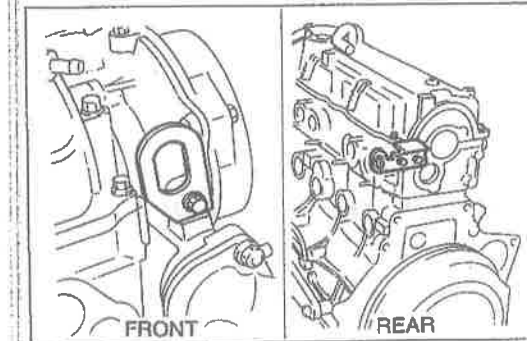

9BU0B1-110

Engine Hanger

- Install the front and rear engine hangers.

Tightening torque:

19—30 N·m (1.9—3.1 m·kg, 14—22 ft·lb)

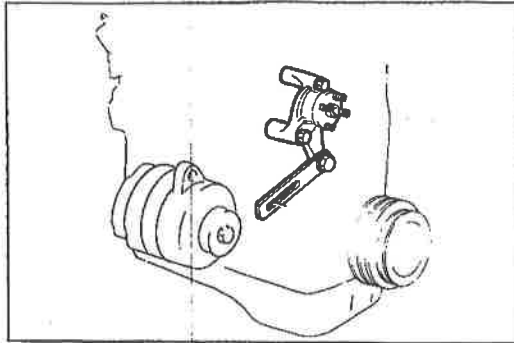

9BU0B1-081

Cooling Fan Bracket

Install the cooling fan bracket.

Tightening torque:

63—93 N·m (6.4—9.5 m·kg, 46—69 ft·lb)

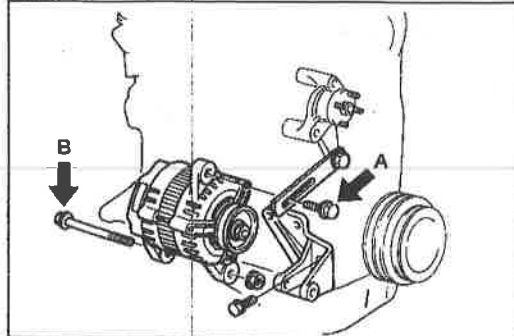

9BU0B1-082

Alternator and Alternator Bracket

1. Install the alternator bracket.

Tightening torque:

37—63 N·m (3.8—6.4 m·kg, 27—46 ft·lb)

2. Install the alternator.

Tightening torque

Bolt A: 31—46 N·m (3.2—4.7 m·kg, 23—34 ft·lb)

Bolt B: 37—52 N·m (3.8—5.3 m·kg, 27—38 ft·lb)

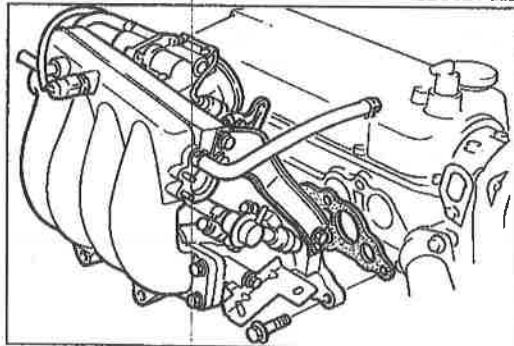

0BU0B1-011

Intake Manifold Assembly

1. Place the new gasket in position.
2. Install the intake manifold assembly.
3. Tighten the bolts and nuts in two or three steps.

Tightening torque:

19—25 N·m (1.9—2.6 m·kg, 14—19 ft·lb)

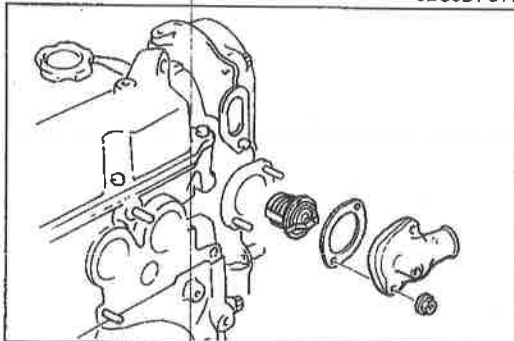

9MU0B2-207

Thermostat and Thermostat Cover

1. Install the thermostat into the water outlet with the jiggle pin at the top.
2. Position a new gasket with the printed side facing the water outlet.
3. Install the thermostat cover.

Tightening torque:

19—25 N·m (1.9—2.6 m·kg, 14—19 ft·lb)

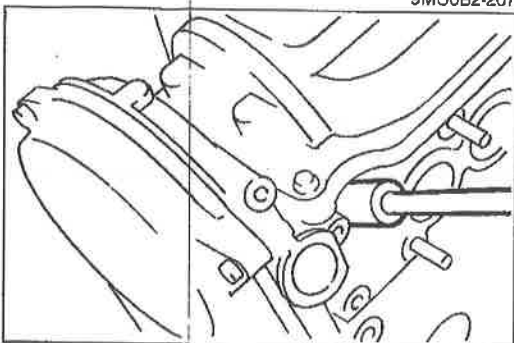

86U01X-219

Spark Plug

1. Apply anti-seize compound or molybdenum-based lubricant to the spark plug threads.
2. Install the spark plugs.

Tightening torque:

15—23 N·m (1.5—2.3 m·kg, 11—17 ft·lb)

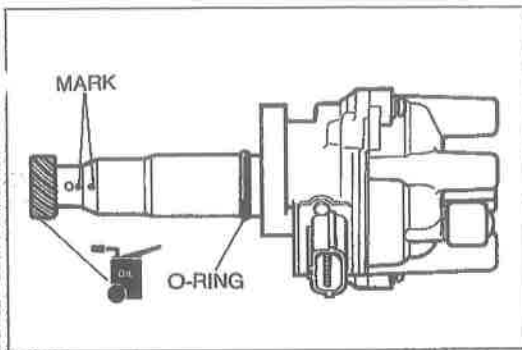

9BU0B1-111

Distributor

1. Verify that the crankshaft pulley timing mark (yellow) is aligned with the matching mark on the timing belt cover.
2. Apply engine oil to the O-ring and install it onto the distributor.
3. Apply engine oil to the distributor driven gear.
4. Align the marks and install the distributor.
5. Loosely tighten the distributor mounting bolt.

High-tension Lead

Install the high-tension leads.

ENGINE STAND REMOVAL

REMOVAL

1. Remove the engine from the engine stand.
2. Remove the **SST** from the engine.
3. Install in the following sequence.

Torque Specifications

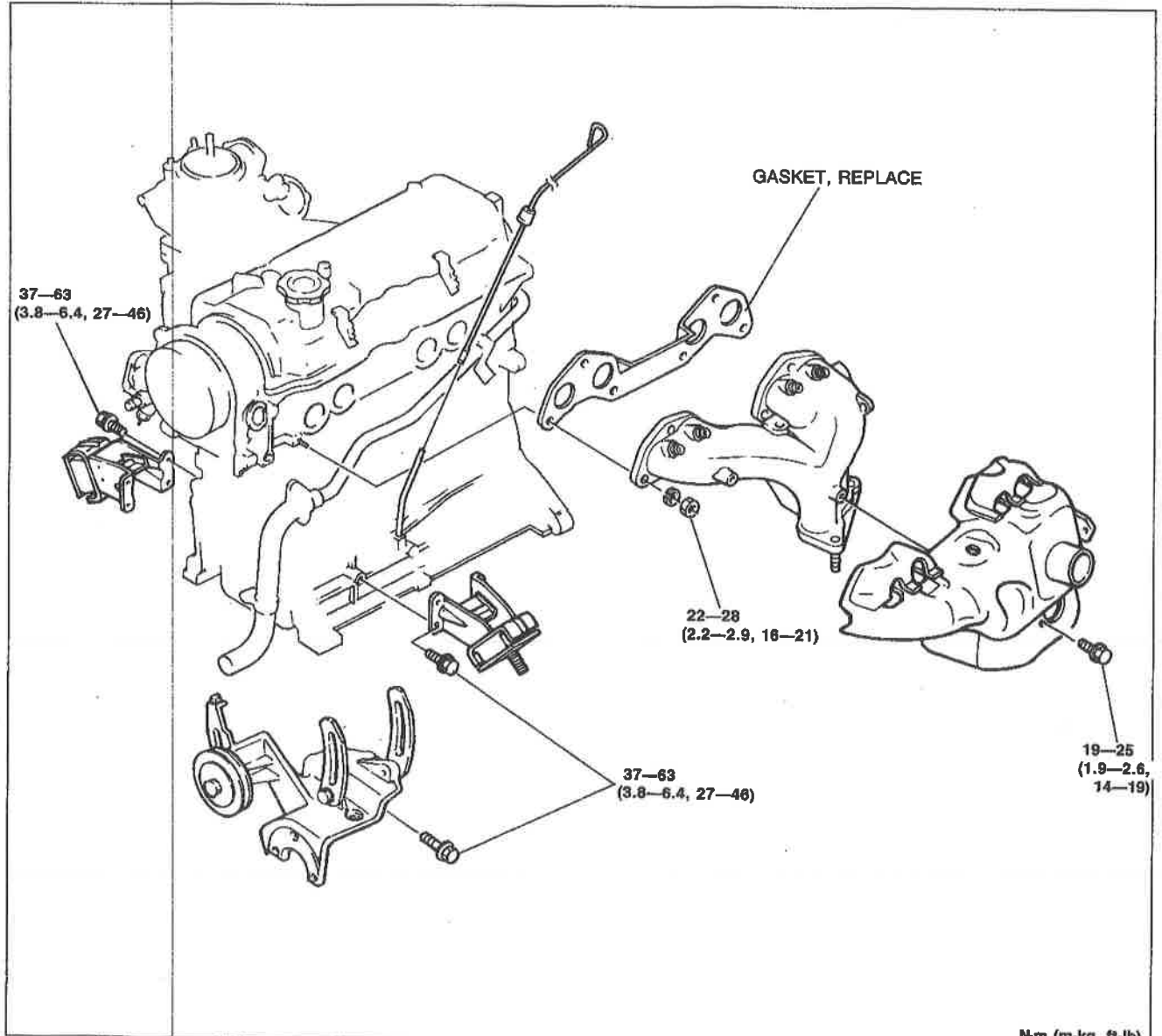

N·m (m·kg, ft·lb)

9MU0B2-213

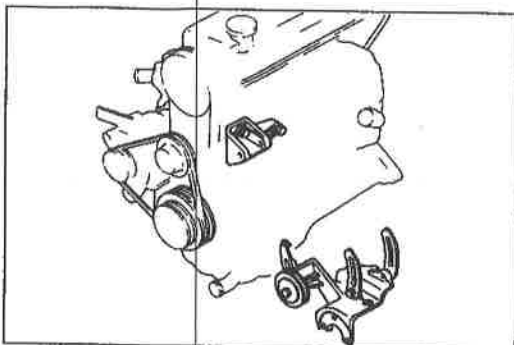

A/C Compressor and P/S Oil Pump Bracket
Install the A/C compressor and P/S oil pump bracket.

Tightening torque:
37-63 N·m (3.8-6.4 m·kg, 27-46 ft·lb)

9BU0B1-084

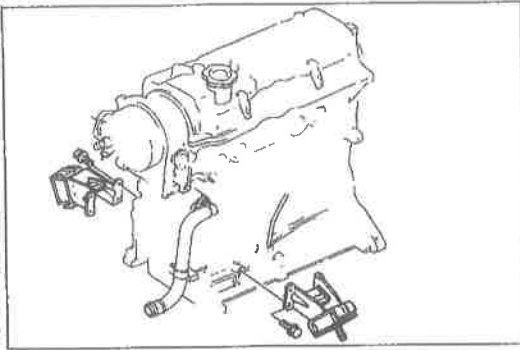

9BU0B1-085

Engine Mount

Install the right and left engine mounts.

Tightening torque:

37—63 N·m (3.8—6.4 m·kg, 27—46 ft·lb)

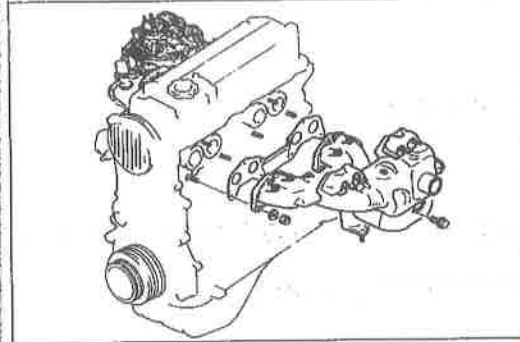

9BU0B1-086

Exhaust Manifold

1. Install the exhaust manifold with a new gasket.
2. Tighten the nuts in two or three steps.

Tightening torque:

22—28 N·m (2.2—2.9 m·kg, 16—21 ft·lb)

Exhaust Manifold Insulator

Install the exhaust manifold insulator.

Tightening torque:

19—25 N·m (1.9—2.6 m·kg, 14—19 ft·lb)

INSTALLATION

PREPARATION SST

49 W023 585A

Adjust wrench



9MU0B2-223

Warning: Be sure the vehicle is securely supported.

1. Install in the reverse order of removal referring to the **Installation note**.
2. Tighten all bolts and nuts to the specified torque.

Caution

After radiator cowl installation, rotate the cooling fan by hand and verify that the fan blade does not touch the radiator cowl.

If the fan touches the cowl, adjust the radiator cowl mounting position.

Note

a) Position the hose clamp in the original location on the hose.

b) Squeeze the clamp lightly with large pliers to ensure a good fit.

Torque Specifications

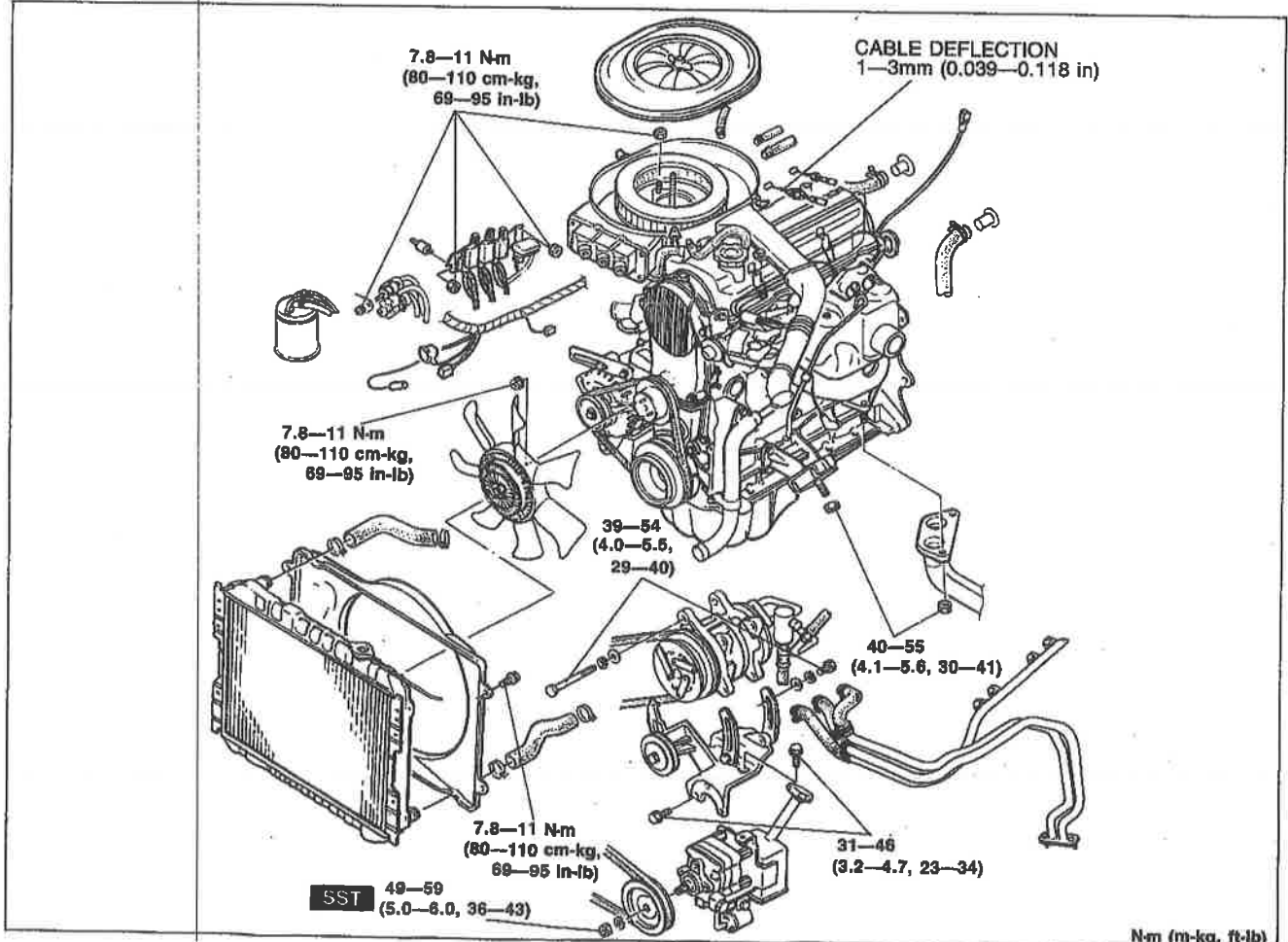

N·m (m·kg, ft·lb)

9BU0B1-087

B1-69

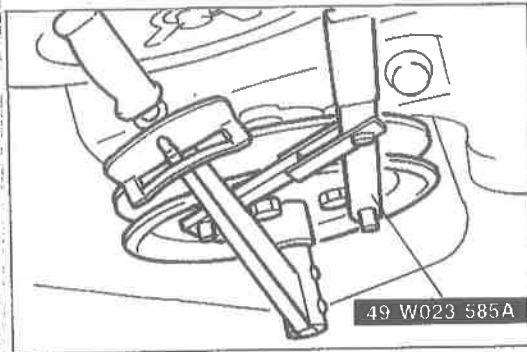

9BU0B1-088

Installation note

P/S Oil Pump

1. Install the P/S oil pump.

Tightening torque:

31—46 N·m (3.2—4.7 m·kg, 23—34 ft·lb)

2. Install the P/S oil pump pulley with the **SST**.

Tightening torque:

49—59 N·m (5.0—6.0 m·kg, 36—43 ft·lb)

Accelerator Cable

Install the accelerator cable.

Cable deflection: 1—3mm (0.039—0.118 in)

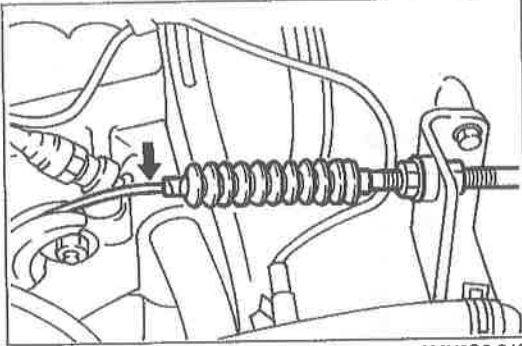

9MU0B2-246

Drive Belt

Install and adjust the drive belt deflection.

(Refer to page B1-5.)

Note

Alternator drive belt can be adjusted after cooling fan installation.

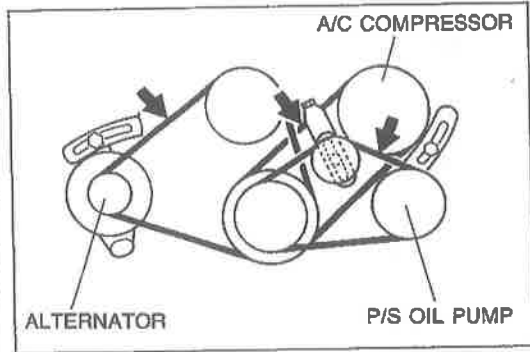

9BU0B1-089

Engine Oil

Add the specified amount and type of engine oil. (Refer to Section D.)

Coolant

Close the drain plug; then fill the radiator and reservoir tank with the specified amount and type of coolant. (Refer to Section E.)

Transmission

Install the manual transmission. (Refer to Section J.)
Install the automatic transmission. (Refer to Section K.)

Starter

Install the starter. (Refer to Section G.)

Check Engine Condition

1. Check for leaks.
2. Connect the negative battery cable.
3. Perform engine adjustments if necessary.
4. Perform a road test.
5. Recheck the oil and coolant levels.

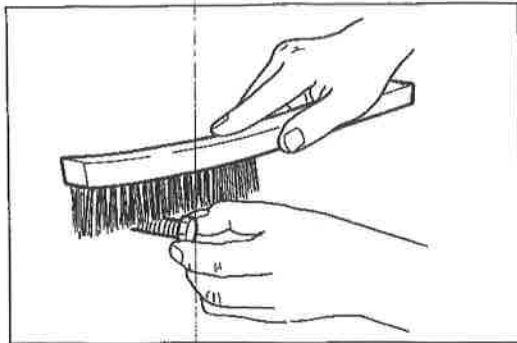

86U01X-138

Flywheel (M/T), Drive Plate (A/T)

1. Remove any old sealant from the bolts and bolt holes. If old sealant cannot be removed from the bolt, replace it.
2. Apply sealant to the bolt threads.

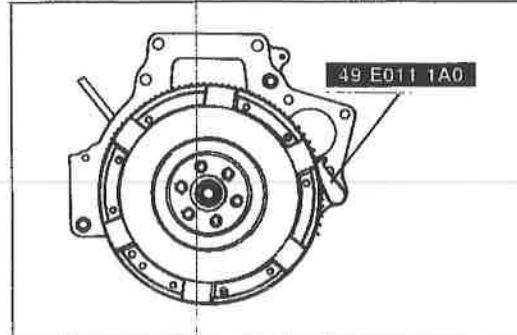

86U01X-139

(M/T)

3. Install, and tighten the flywheel with the **SST**.

Tightening torque:

96—103 N·m (9.8—10.5 m·kg, 71—76 ft·lb)

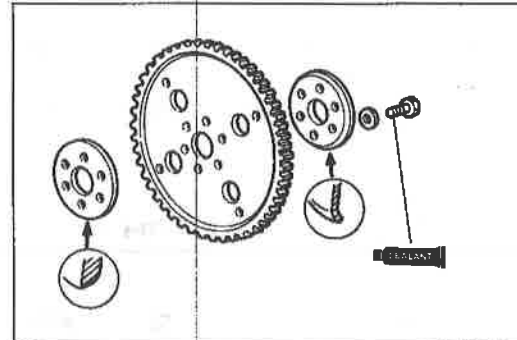

76F01C-049

(A/T)

4. Install, and tighten the drive plate adapter, drive plate, and backing plate with the **SST**.

Tightening torque:

96—103 N·m (9.8—10.5 m·kg, 71—76 ft·lb)

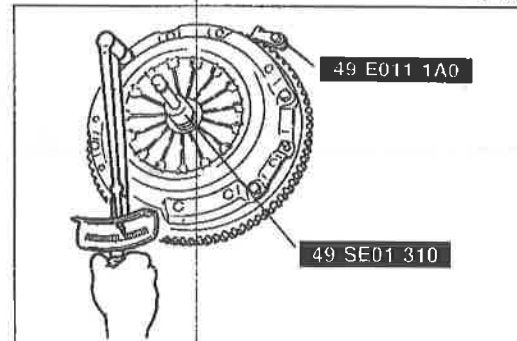

98U0B1-071

Clutch Disc and Clutch Cover (M/T)

Install the clutch disc and clutch cover using the **SST**. (Refer to Section H.)

Tightening torque:

18—26 N·m (1.8—2.7 m·kg, 13—20 ft·lb)

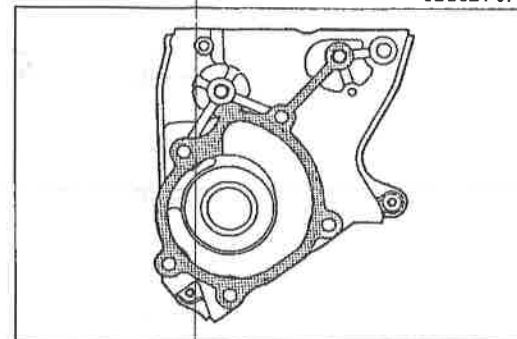

96U01X-053

Water Pump

1. Remove all dirt, grease, and other material from the water pump mounting surface.
2. Place a new gasket in position.

ASSEMBLY (CYLINDER HEAD)

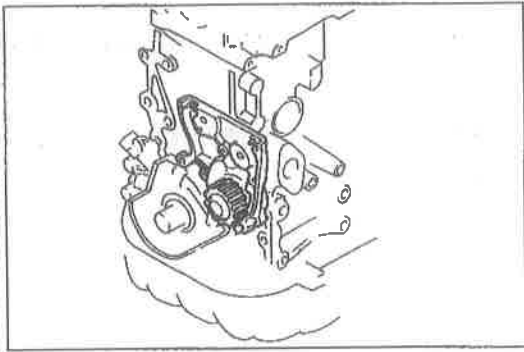

7BU01B-103

3. Install the water pump.

Tightening torque:
19—25 N·m (1.9—2.6 m·kg, 14—19 ft·lb)

CYLINDER HEAD Torque Specifications

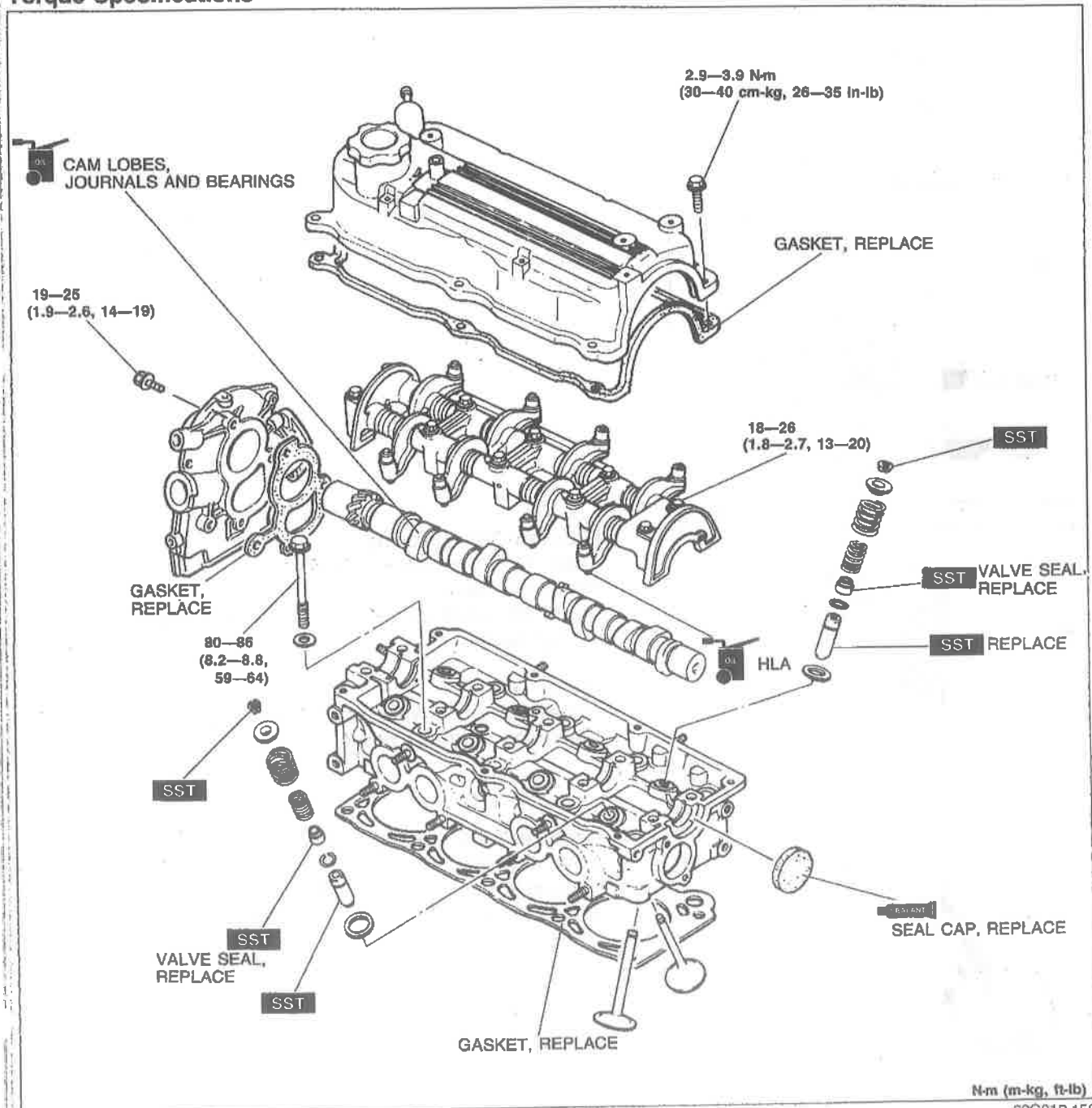

69G01B-152

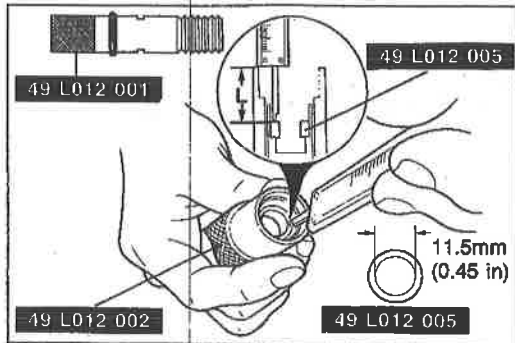

9BU0B1-072

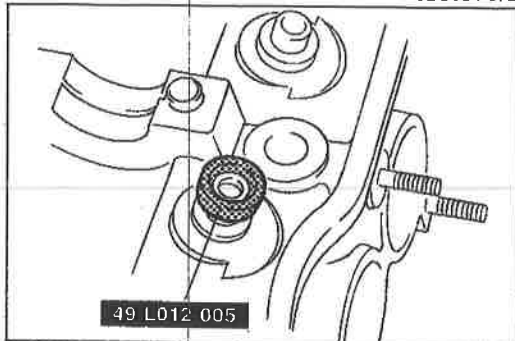

0BU0B1-022

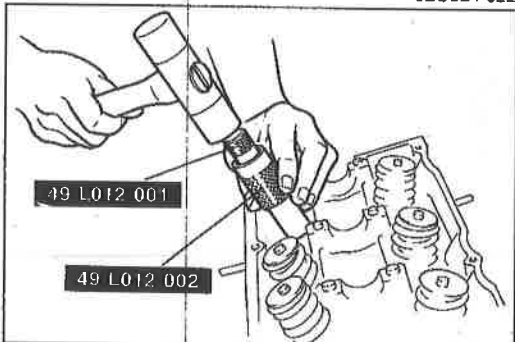

9MU0B2-190

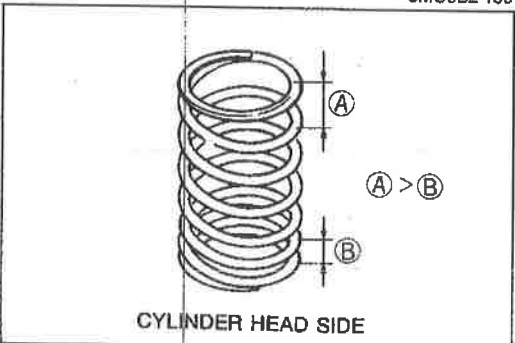

9BU0B1-073

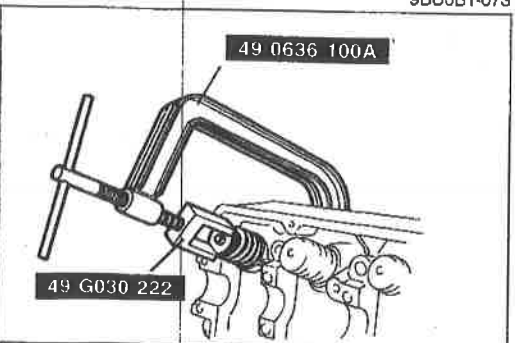

86U01X-145

Valve Seal

1. Assemble the **SST** as shown so that the depth **L** is as specified.

Depth L: 21.6—22.0mm (0.850—0.866 in)

2. Install a new valve seal onto the valve guide.
3. Install the **SST** onto the valve seal.

4. Tap the valve seal in until the **SST** contacts the cylinder head.

Valve and Valve Spring

1. Install the lower spring seat.
2. Install the valve.
3. Install the valve springs (outer and inner) and the upper spring seat.

Note

Install the outer valve spring with the closer pitch toward the cylinder head.

4. Compress the valve spring with the **SST**; then install the valve keepers.
5. Tap the end of the valve stem lightly two or three times with a plastic hammer to confirm that the keepers are all fully seated.

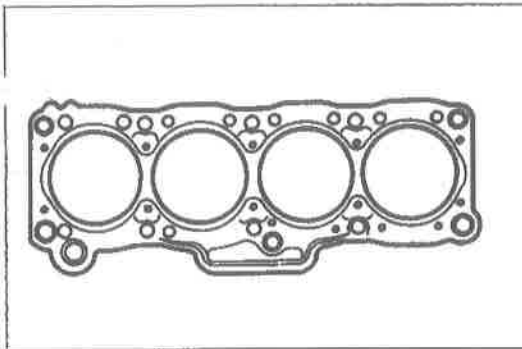

86U01X-146

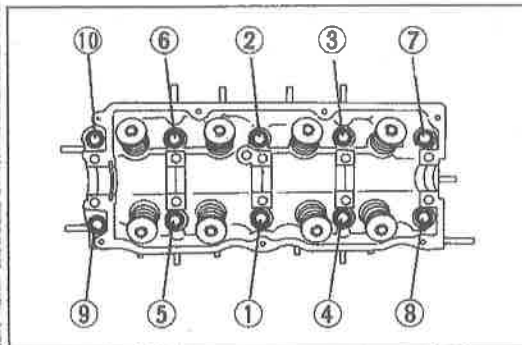

86U01X-147

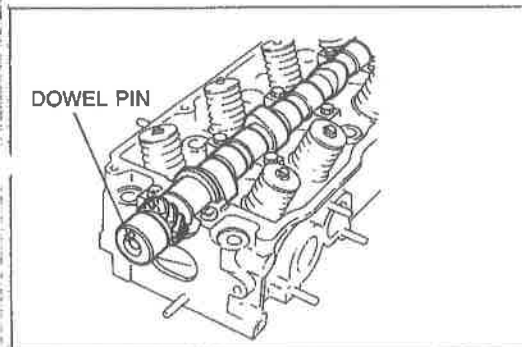

86U01X-148

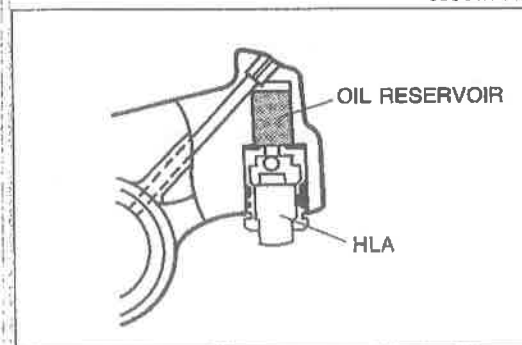

86U01X-149

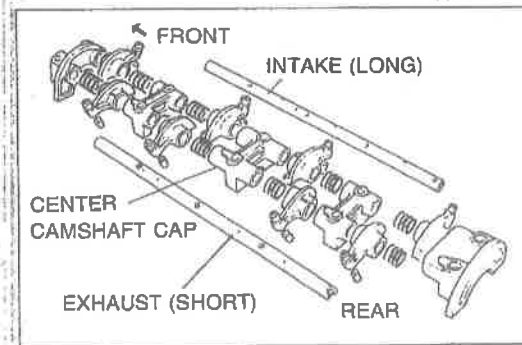

98U0B1-074

Cylinder Head

1. Thoroughly remove all dirt, oil, or other material from the top of the cylinder block.
2. Place the new cylinder head gasket in position.

3. Install the cylinder head.
4. Apply engine oil to the bolt threads and seat faces.
5. Tighten the cylinder head bolts in two or three steps in the order shown in the figure.

Tightening torque:

80—86 N·m (8.2—8.8 m·kg, 59—64 ft·lb)

Camshaft

1. Apply a liberal amount of engine oil to the journals and bearings.
2. Place the camshaft in position with the dowel pin facing straight up.

Hydraulic Lash Adjuster (HLA)

1. Pour engine oil into the oil reservoir in the rocker arm.
2. Apply engine oil to the new HLA.
3. Carefully install the HLA into the rocker arm.

Caution

Be careful not to damage the O-ring when installing the HLA.

Camshaft Cap, Rocker Arm and Shaft Assembly

1. Assemble the rocker arm and shaft assembly as shown in the figure.

Caution

Be sure that rocker arm shaft oil holes (in the center camshaft cap) face each other.

Note

Use the installation bolts for alignment.

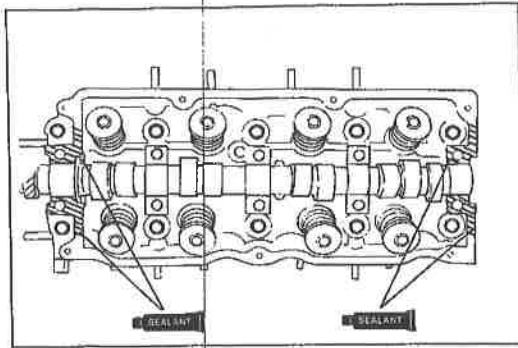

9BU0B1-075

2. Apply silicone sealant to the shaded areas shown in the figure.
3. Apply liberal amount of clean engine oil to the cam lobes and journals.

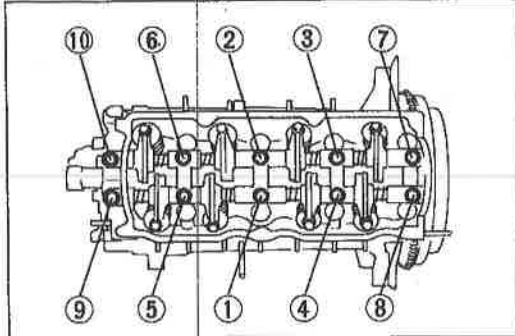

9BU0B1-076

4. Install the rocker arm and shaft assemblies. Tighten the bolts in two or three steps in the order shown in the figure.

Tightening torque:

18—26 N·m (1.8—2.7 m·kg, 13—20 ft·lb)

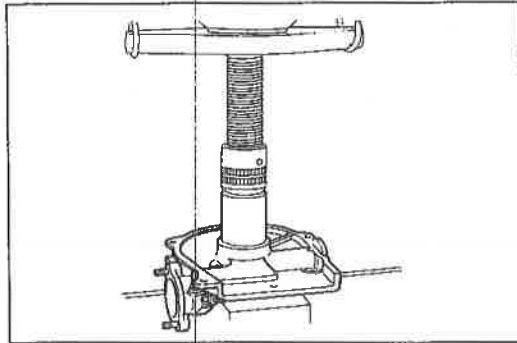

86U01X-155

Front Housing

1. Apply engine oil to the front housing and a new oil seal.
2. Press the oil seal into the front housing.

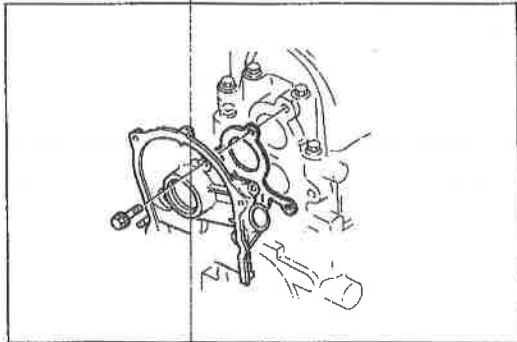

86U01X-156

3. Apply engine oil to the oil seal lip.
4. Install the front housing and a new gasket.

Tightening torque:

19—25 N·m (1.9—2.6 m·kg, 14—19 ft·lb)

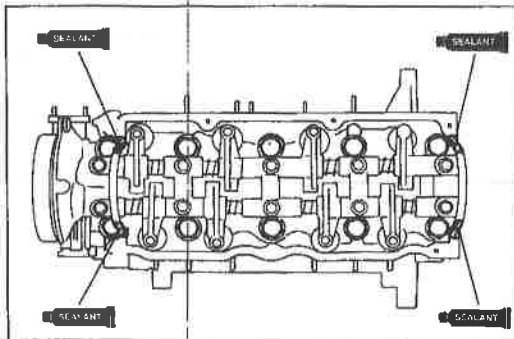

9BU0B1-105

Cylinder Head Cover

1. Apply silicon sealant to the shaded areas shown in the figure.
2. Install the cylinder head cover.

Tightening torque:

2.9—3.9 N·m (30—40 cm·kg, 26—35 in·lb)

B1

ASSEMBLY (TIMING BELT)

TIMING BELT Torque Specifications

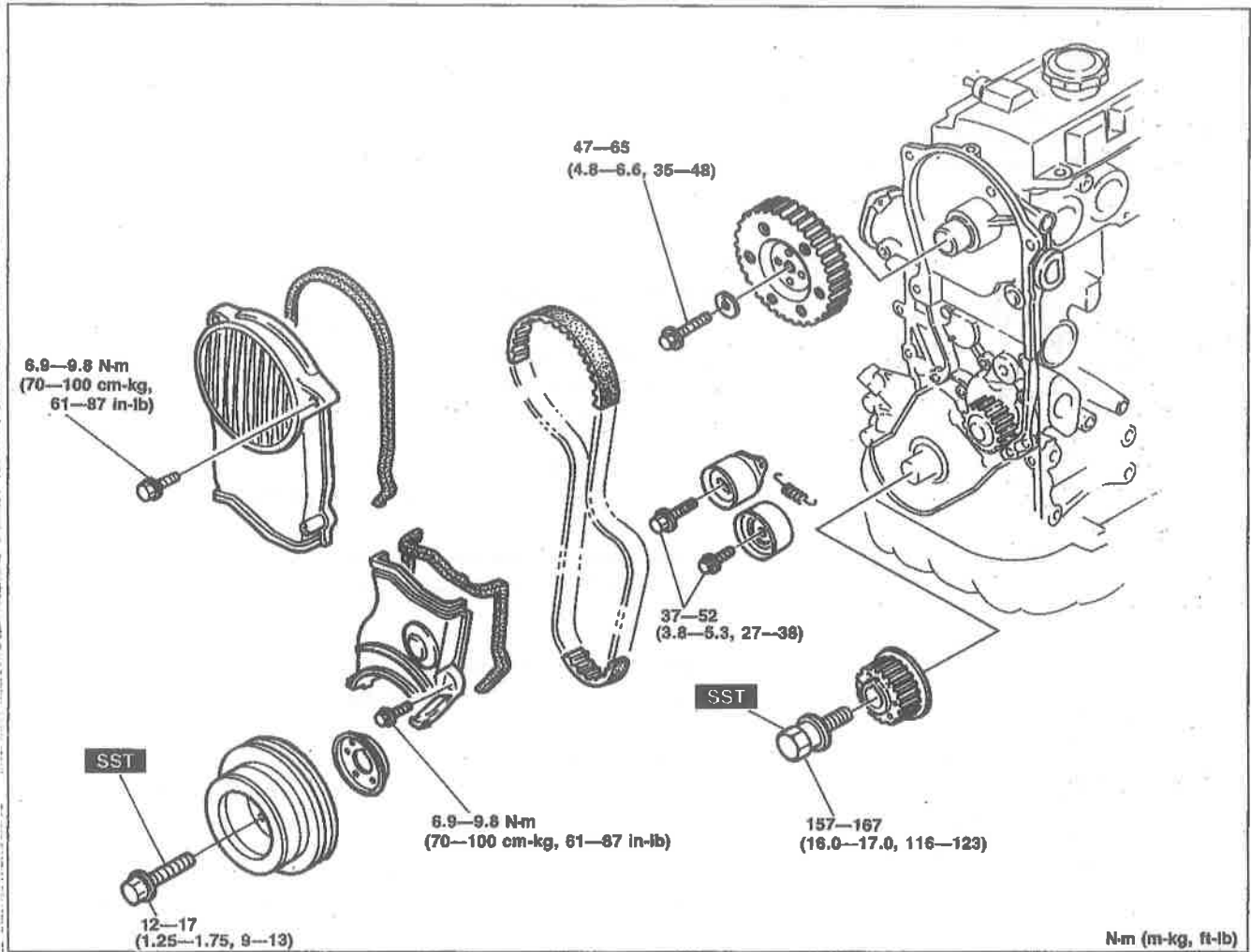

N-m (m-kg, ft-lb)

69G01B-160

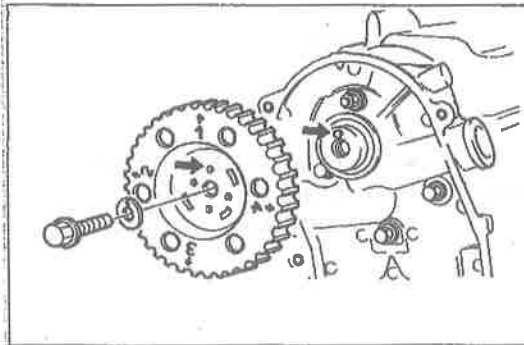

96U01X-056

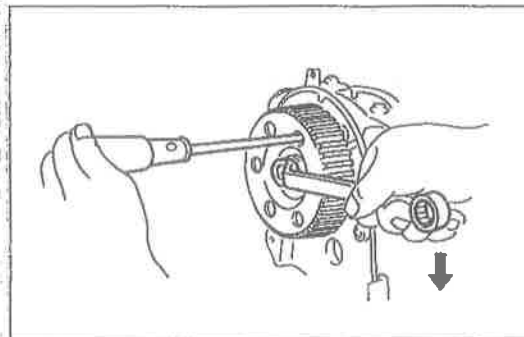

76G01A-141

Camshaft Pulley

1. Install the camshaft pulley on the camshaft with the dowel pin fit into the hole at the **↑1** mark.

2. Tighten the camshaft pulley lock bolt.

Tightening torque:

47-65 N-m (4.8-6.6 m-kg, 35-48 ft-lb)

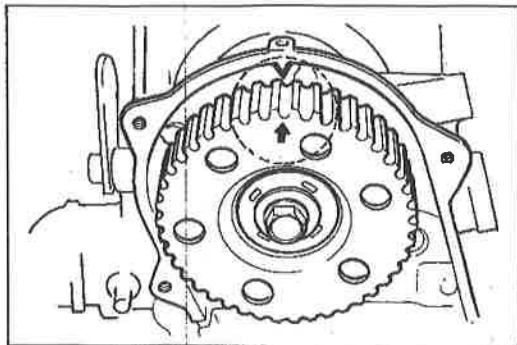

96U01X-057

- Align the **↑1** mark on the pulley with the matching mark on the front housing.

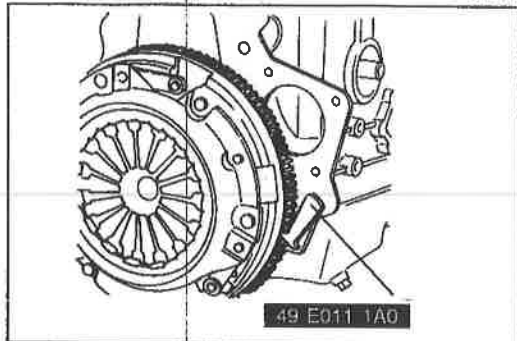

0BU0B1-015

Timing Belt Pulley

- Reverse the direction of the **SST**. (Refer to page B1-55.)
- Install the crankshaft key.
- Install the timing belt pulley on the crankshaft.

Tightening torque:

157—167 N·m (16.0—17.0 m·kg, 116—123 ft·lb)

- Release the ring gear brake.
- Align the timing belt pulley and the oil pump body matching marks.

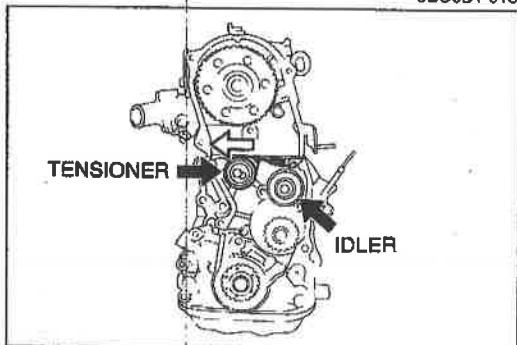

69G01B-165

Timing Belt Idler Pulley

Install the timing belt idler pulley.

Tightening torque:

37—52 N·m (3.8—5.3 m·kg, 27—38 ft·lb)

Timing Belt Tensioner

- Install the timing belt tensioner and tensioner spring.
- Tentatively secure the tensioner with the spring fully extended.

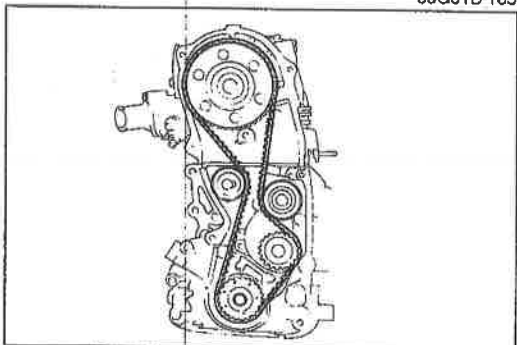

76G01A-085

Timing Belt

- Install the timing belt. (keep the tension side of belt as tight as possible.)

Caution

- If the timing belt is being reused, it must be reinstalled to rotate in the original direction.
- Check that there is no oil, grease, or dirt on the timing belt.

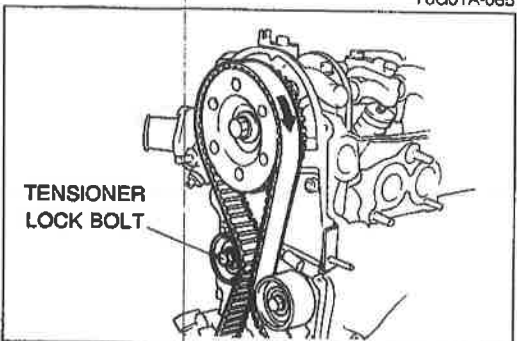

96U01X-059

- Turn the crankshaft twice in the direction of rotation.
- Check that the matching marks are correctly aligned. If not aligned, remove the timing belt and tensioner, and repeat the above-mentioned procedure.
- Loosen the tensioner lock bolt and apply tension to the belt.

ASSEMBLY (TIMING BELT)

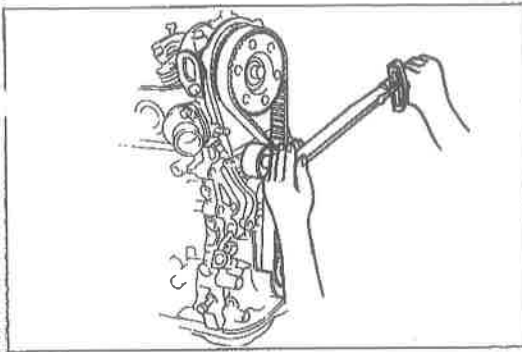

96U01X-060

5. Tighten the timing belt tensioner lock bolt.

Tightening torque:

37—52 N·m (3.8—5.3 m·kg, 27—38 ft·lb)

6. Turn the crankshaft twice in the direction of rotation and align the matching marks.

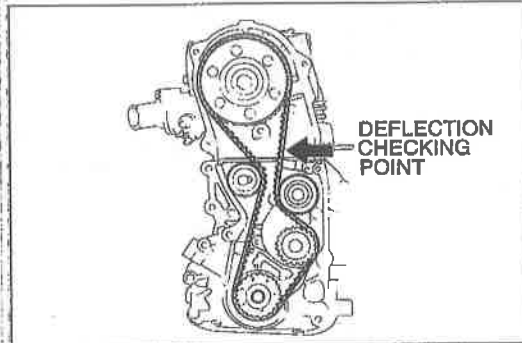

9BU0B1-077

7. Check the timing belt deflection.

If the deflection is not correct, loosen the tensioner lock bolt and repeat steps 3—5 above. Replace the tensioner spring if necessary.

Belt deflection/98 N (10 kg, 22 lb)

New : 8.0—9.0mm (0.31—0.35 in)

Used: 9.0—10.0mm (0.35—0.39 in)

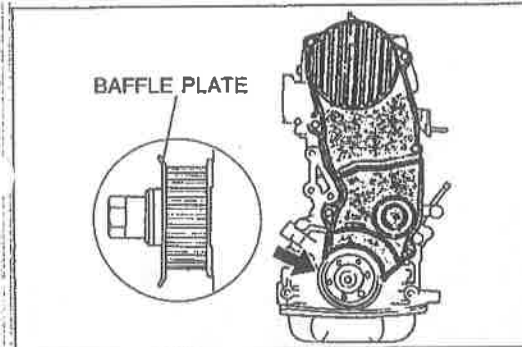

9BU0B1-107

Baffle Plate

Position the baffle plate on the timing belt pulley.

Timing Belt Cover

Install the lower timing belt cover, upper timing belt cover, and new gaskets.

Tightening torque:

6.9—9.8 N·m (70—100 cm·kg, 61—87 in·lb)

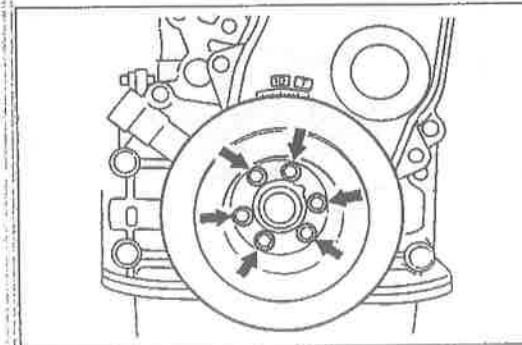

9BU0B1-108

Crankshaft Pulley

Install the crankshaft pulley.

Tightening torque:

12—17 N·m (1.25—1.75 m·kg, 9—13 ft·lb)

AUXILIARY PARTS Torque Specification

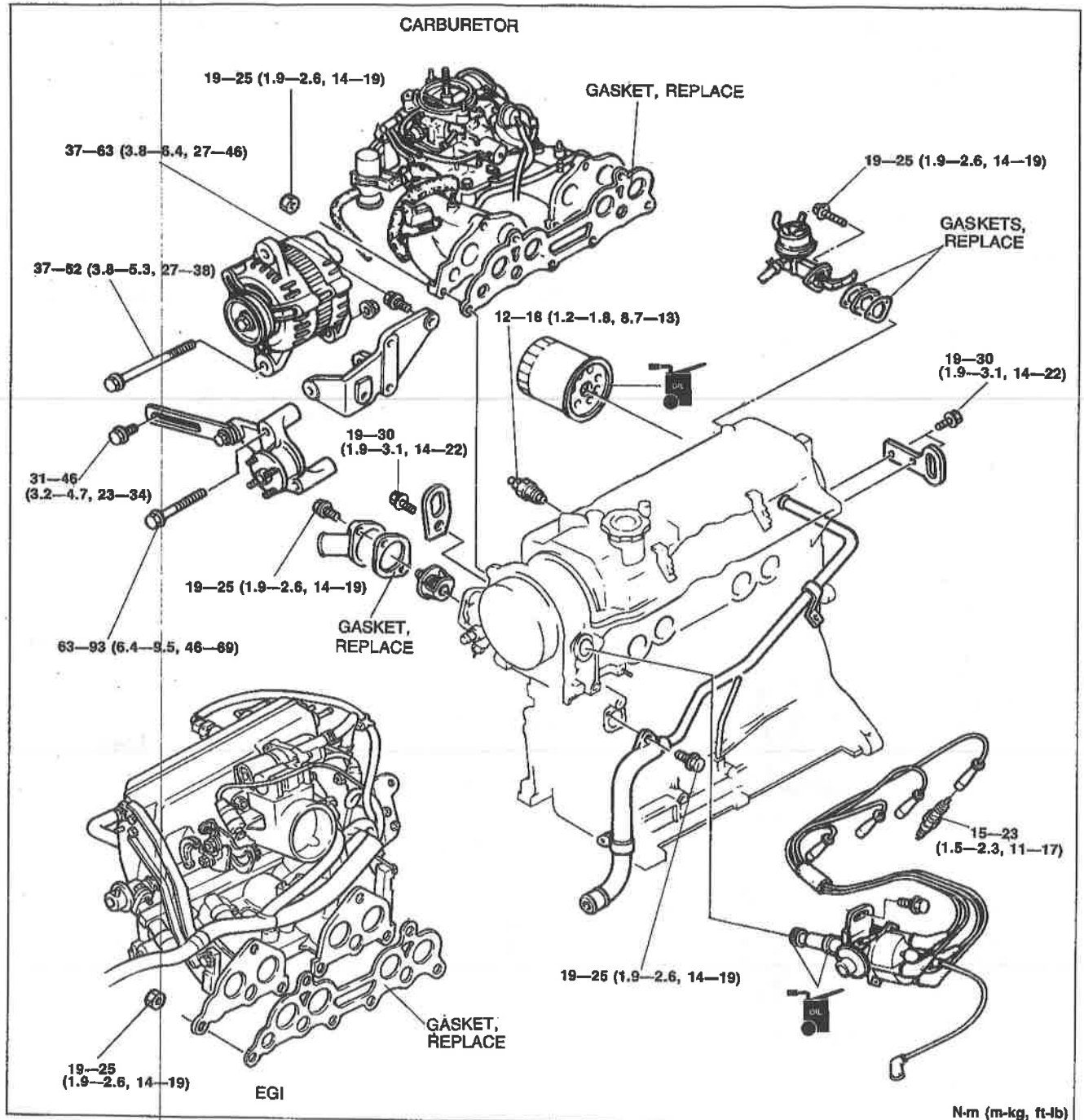

9MU0B2-201

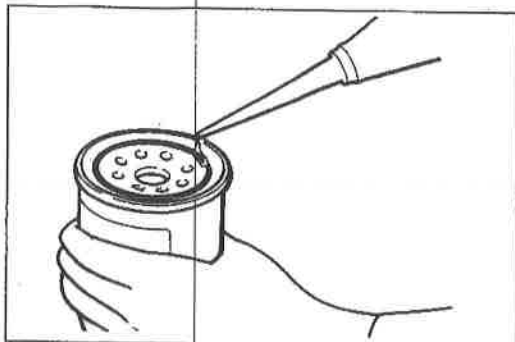

9BU0B1-078

Oil Pressure Switch
Install the oil pressure switch.

Tightening torque:
12-18 N-m (1.2-1.8 m-kg, 8.7-13 ft-lb)

Oil Filter

1. Apply a small amount of engine oil to the rubber seal of the new filter.
2. Install the oil filter and tighten it by hand until the rubber seal contacts the base.
3. Then tighten the filter 1-1/6 turn with a wrench.

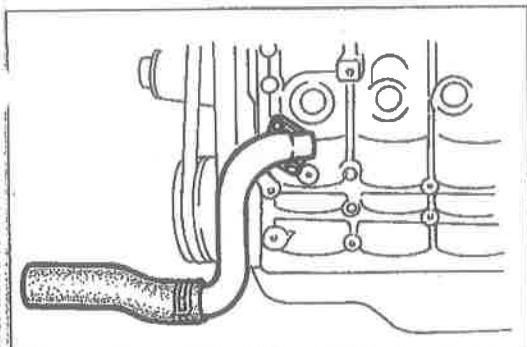

9MU0B2-214

Coolant Inlet Pipe and Bypass Pipe

1. Install the coolant inlet pipe with a new gasket.

Tightening torque:

19—25 N·m (1.9—2.6 m·kg, 14—19 ft·lb)

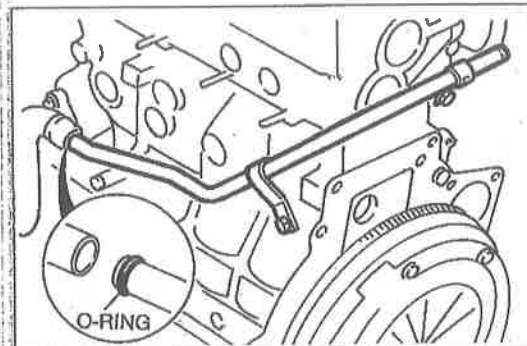

9BU0B1-109

2. Apply vegetable oil to the new O-ring.
3. Install the coolant bypass pipe.

Tightening torque:

19—25 N·m (1.9—2.6 m·kg, 14—19 ft·lb)

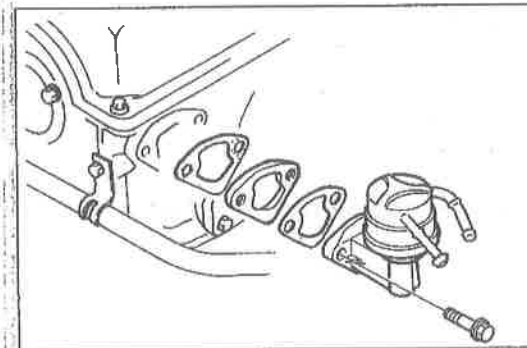

0BU0B1-010

Fuel Pump (Carburetor M/T)

1. Apply engine oil to the fuel cam contact surface.
2. Install the fuel pump with the insulator and new gaskets.

Tightening torque:

19—25 N·m (1.9—2.6 m·kg, 14—19 ft·lb)

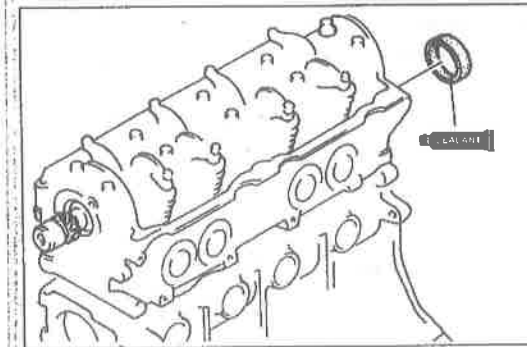

9BU0B1-080

Seal Cap

1. Apply silicone sealant to the new seal cap.
2. Install the seal cap into the cylinder head.

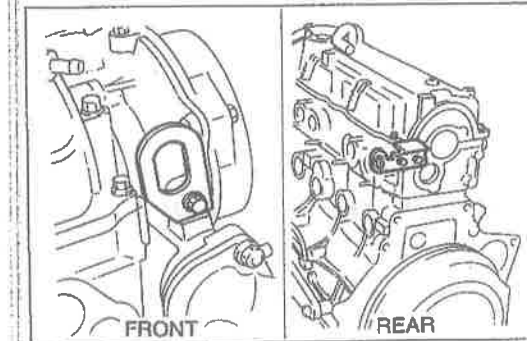

9BU0B1-110

Engine Hanger

- Install the front and rear engine hangers.

Tightening torque:

19—30 N·m (1.9—3.1 m·kg, 14—22 ft·lb)

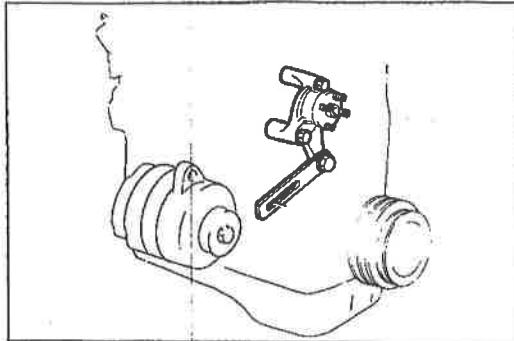

9BU0B1-081

Cooling Fan Bracket

Install the cooling fan bracket.

Tightening torque:

63—93 N·m (6.4—9.5 m·kg, 46—69 ft·lb)

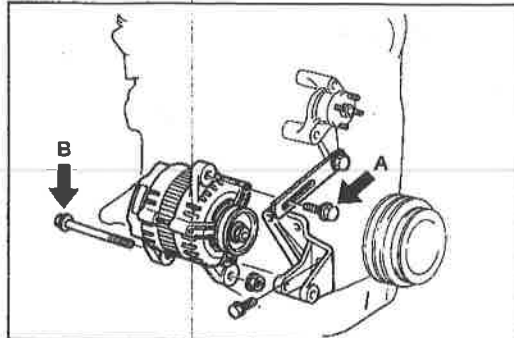

9BU0B1-082

Alternator and Alternator Bracket

1. Install the alternator bracket.

Tightening torque:

37—63 N·m (3.8—6.4 m·kg, 27—46 ft·lb)

2. Install the alternator.

Tightening torque

Bolt A: 31—46 N·m (3.2—4.7 m·kg, 23—34 ft·lb)

Bolt B: 37—52 N·m (3.8—5.3 m·kg, 27—38 ft·lb)

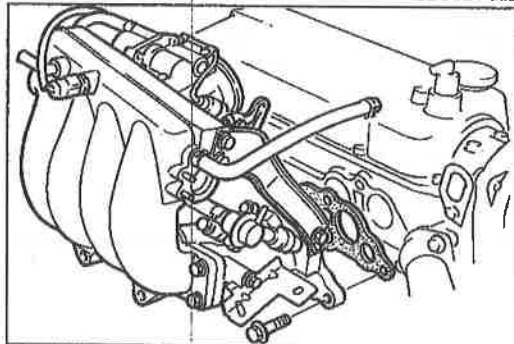

0BU0B1-011

Intake Manifold Assembly

1. Place the new gasket in position.
2. Install the intake manifold assembly.
3. Tighten the bolts and nuts in two or three steps.

Tightening torque:

19—25 N·m (1.9—2.6 m·kg, 14—19 ft·lb)

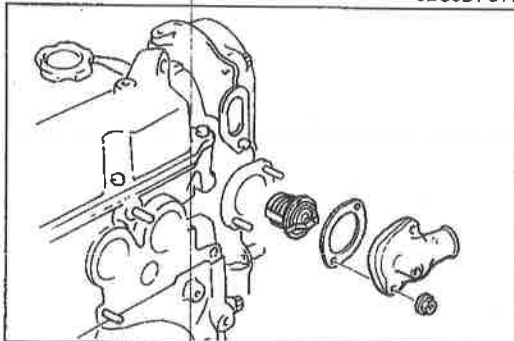

9MU0B2-207

Thermostat and Thermostat Cover

1. Install the thermostat into the water outlet with the jiggle pin at the top.
2. Position a new gasket with the printed side facing the water outlet.
3. Install the thermostat cover.

Tightening torque:

19—25 N·m (1.9—2.6 m·kg, 14—19 ft·lb)

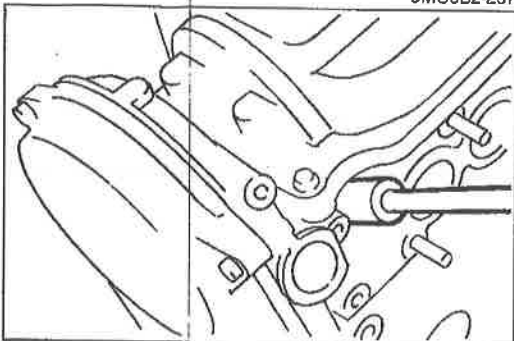

86U01X-219

Spark Plug

1. Apply anti-seize compound or molybdenum-based lubricant to the spark plug threads.
2. Install the spark plugs.

Tightening torque:

15—23 N·m (1.5—2.3 m·kg, 11—17 ft·lb)

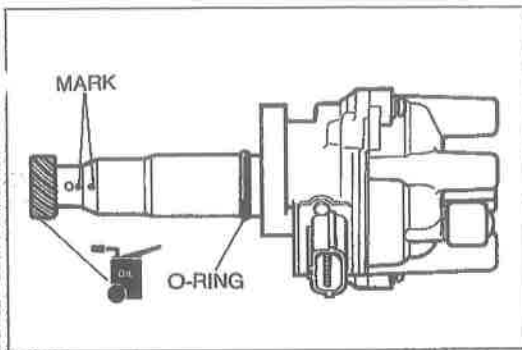

9BU0B1-111

Distributor

1. Verify that the crankshaft pulley timing mark (yellow) is aligned with the matching mark on the timing belt cover.
2. Apply engine oil to the O-ring and install it onto the distributor.
3. Apply engine oil to the distributor driven gear.
4. Align the marks and install the distributor.
5. Loosely tighten the distributor mounting bolt.

High-tension Lead

Install the high-tension leads.

ENGINE STAND REMOVAL

REMOVAL

1. Remove the engine from the engine stand.
2. Remove the **SST** from the engine.
3. Install in the following sequence.

Torque Specifications

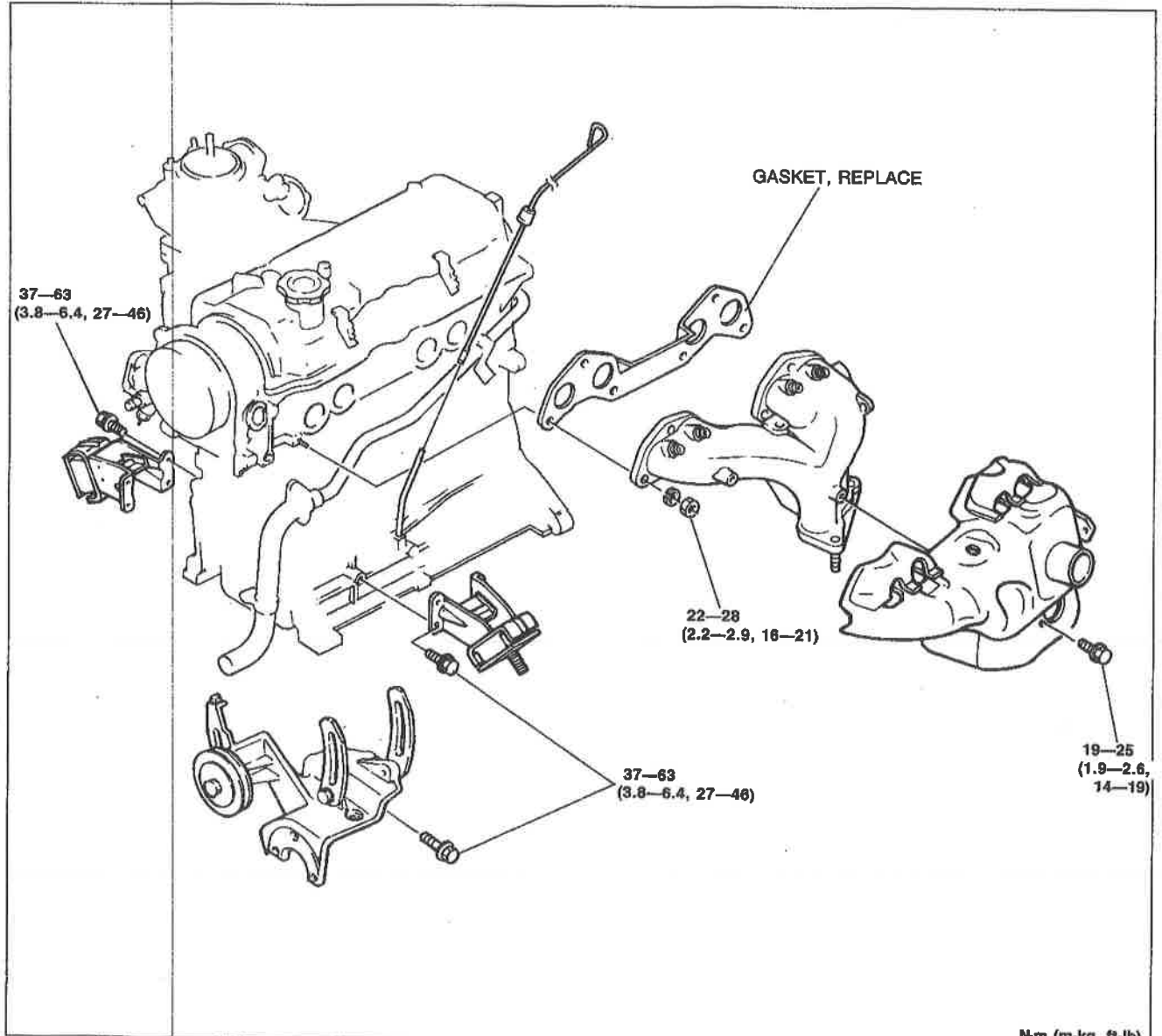

N-m (m-kg, ft-lb)
9MU0B2-213

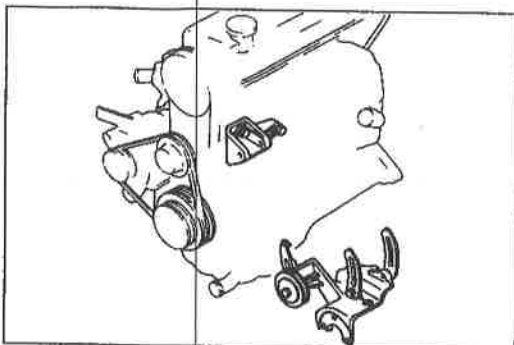

A/C Compressor and P/S Oil Pump Bracket
Install the A/C compressor and P/S oil pump bracket.

Tightening torque:
37-63 N-m (3.8-6.4 m-kg, 27-46 ft-lb)

9BU0B1-084

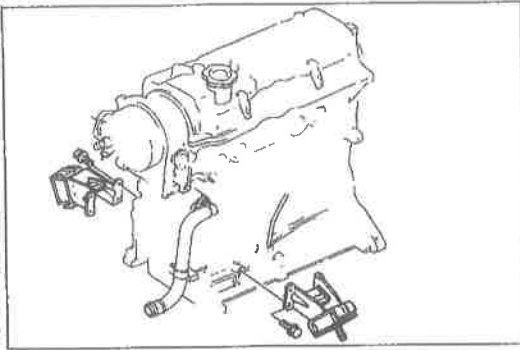

9BU0B1-085

Engine Mount

Install the right and left engine mounts.

Tightening torque:

37—63 N·m (3.8—6.4 m·kg, 27—46 ft·lb)

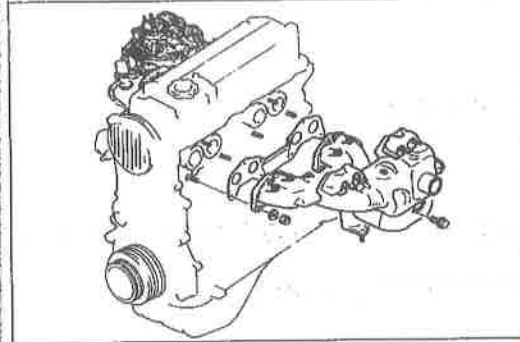

9BU0B1-086

Exhaust Manifold

1. Install the exhaust manifold with a new gasket.
2. Tighten the nuts in two or three steps.

Tightening torque:

22—28 N·m (2.2—2.9 m·kg, 16—21 ft·lb)

Exhaust Manifold Insulator

Install the exhaust manifold insulator.

Tightening torque:

19—25 N·m (1.9—2.6 m·kg, 14—19 ft·lb)

INSTALLATION

PREPARATION SST

49 W023 585A
Adjust wrench



9MU0B2-223

Warning: Be sure the vehicle is securely supported.

1. Install in the reverse order of removal referring to the **Installation note**.
2. Tighten all bolts and nuts to the specified torque.

Caution

After radiator cowl installation, rotate the cooling fan by hand and verify that the fan blade does not touch the radiator cowl. If the fan touches the cowl, adjust the radiator cowl mounting position.

Note

- a) Position the hose clamp in the original location on the hose.
- b) Squeeze the clamp lightly with large pliers to ensure a good fit.

Torque Specifications

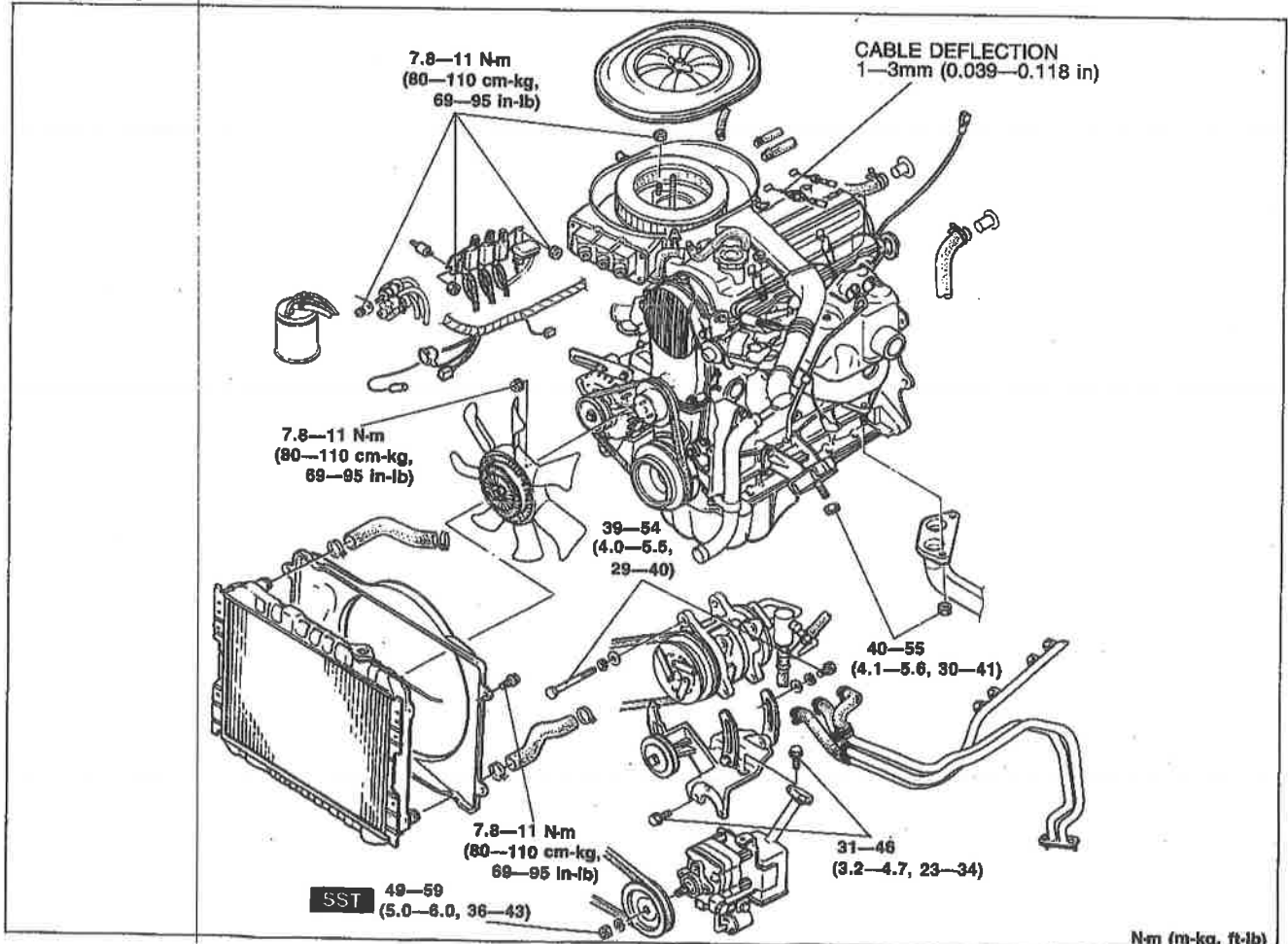

N·m (m·kg, ft·lb)

9BU0B1-087

B1-69

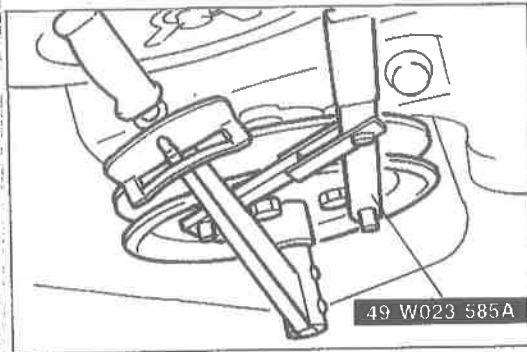

9BU0B1-088

Installation note

P/S Oil Pump

1. Install the P/S oil pump.

Tightening torque:

31—46 N·m (3.2—4.7 m·kg, 23—34 ft·lb)

2. Install the P/S oil pump pulley with the **SST**.

Tightening torque:

49—59 N·m (5.0—6.0 m·kg, 36—43 ft·lb)

Accelerator Cable

Install the accelerator cable.

Cable deflection: 1—3mm (0.039—0.118 in)

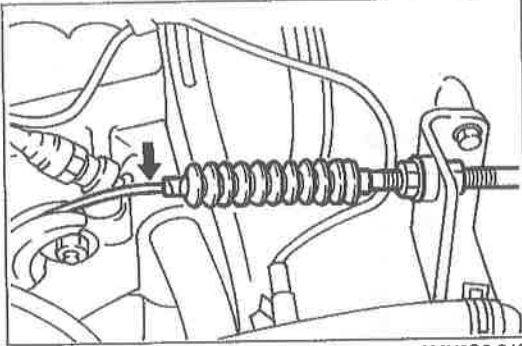

9MU0B2-246

Drive Belt

Install and adjust the drive belt deflection.

(Refer to page B1-5.)

Note

Alternator drive belt can be adjusted after cooling fan installation.

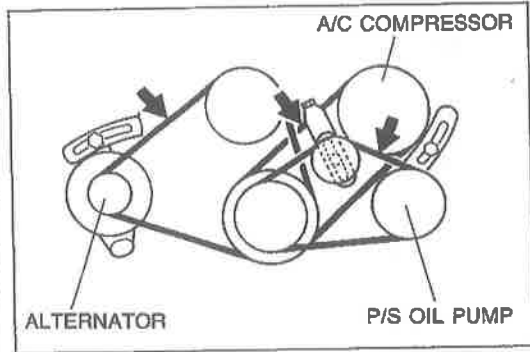

9BU0B1-089

Engine Oil

Add the specified amount and type of engine oil. (Refer to Section D.)

Coolant

Close the drain plug; then fill the radiator and reservoir tank with the specified amount and type of coolant. (Refer to Section E.)

Transmission

Install the manual transmission. (Refer to Section J.)
Install the automatic transmission. (Refer to Section K.)

Starter

Install the starter. (Refer to Section G.)

Check Engine Condition

1. Check for leaks.
2. Connect the negative battery cable.
3. Perform engine adjustments if necessary.
4. Perform a road test.
5. Recheck the oil and coolant levels.